

1
RJ038-010-023-LSP
RJ038-010-024-LSP
x1 Left Side Panel
x1 Panneau Latéral Gauche
x1 Panel Lateral Izquierdo

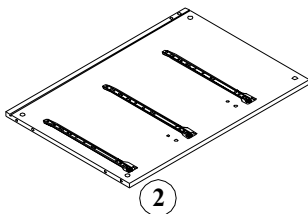

2
RJ038-010-023-RSP
RJ038-010-024-RSP
x1 Right Side Panel
x1 Panneau Côté Droite
x1 Panel Derecho

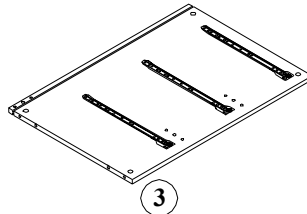

3
RJ038-010-023-CPAN
RJ038-010-024-CPAN
x1 Center Panel
x1 Panneau Central
x1 Panel Central

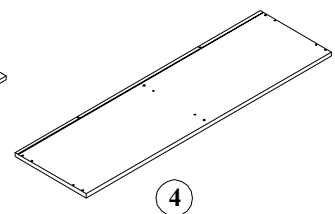

4
RJ038-010-023-TPA
RJ038-010-024-TPA
x1 Top panel
x1 Panneau supérieur
x1 Panel superior

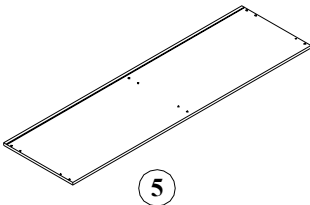

5
RJ038-010-023-BOP
RJ038-010-024-BOP
x1 Bottom Panel
x1 Panneau Inférieur
x1 Panel Inferior

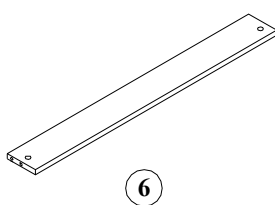

6
RJ038-010-023-FSRA
RJ038-010-024-FSRA
x4 Front Support Rail
x4 Rail de support avant
x4 Riel de soporte delantero

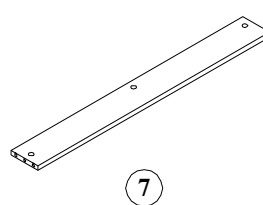

7
RJ038-010-023-BSRA
RJ038-010-024-BSRA
x2 Back Support Rail
x2 Rail de support arrière
x2 Riel de soporte trasero

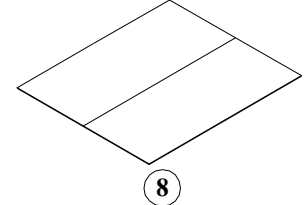

8
RJ038-010-023-BAP
RJ038-010-024-BAP
x2 Back Panel
x2 Panneau Arrière
x2 Panel Posterior

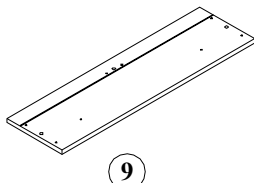

9
RJ038-010-023-DFPA
RJ038-010-024-DFPA
x6 Drawer Front Panel
x6 Panneau avant du tiroir
x6 Panel frontal del cajón

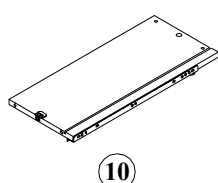

10
RJ038-010-023-DLPA
RJ038-010-024-DLPA
x6 Drawer Left Panel
x6 Panneau gauche du tiroir
x6 Panel izquierdo del cajón

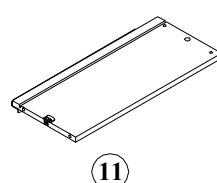

11
RJ038-010-023-DRPA
RJ038-010-024-DRPA
x6 Drawer Right Panel
x6 Panneau droit du tiroir
x6 Panel derecho del cajón



Philips Head screwdriver
(Not included)
Tournevis cruciforme
(Non compris)
Destornillador de estrella
(No incluido)

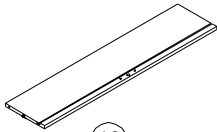

12

RJ038-010-023-DBPA
RJ038-010-024-DBPA
x6 Drawer Back Panel
x6 Panneau arrière du tiroir
x6 Panel trasero del cajón

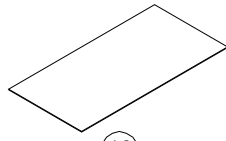

13

RJ038-010-023-DOPA
RJ038-010-024-DOPA
x6 Drawer Bottom Panel
x6 Panneau inférieur du tiroir
x6 Panel inferior del cajón

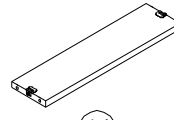

14

RJ038-010-023-DSPA
RJ038-010-024-DSPA
x6 Drawer Support Panel
x6 Panneau de support de tiroir
x6 Panel de soporte de cajón

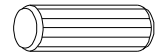

15

RJ038-010-023-WSC1
RJ038-010-024-WSC1
x30 Wood Screw M8 X 25
x30 Vis à bois M8 X 25
x30 Tornillo para madera
M8 X 25



16

RJ038-010-023-WSC2
RJ038-010-024-WSC2
x72 Wood Screw M6 X 25
x72 Vis à bois M6 X 25
x72 Tornillo para madera
M6 X 25



17

RJ038-010-023-BOL
RJ038-010-024-BOL
x26 Cam Bolt
x26 Boulon
x26 Perno



18

RJ038-010-023-CAM
RJ038-010-024-CAM
x26 Cam Housing D15/12.5
x26 Boîtier de came D15/12.5
x26 Carcasa de leva D15/12.5



19

RJ038-010-023-SC1
RJ038-010-024-SC1
x20 Screw M4 x 10
x20 Vis M4 x 10
x20 Tornillo M4 x 10

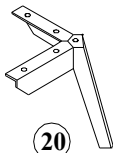

20

RJ038-010-023-LEG
RJ038-010-024-LEG
x4 Leg
x4 Jambe
x4 Pierna



21

RJ038-010-023-HAND
RJ038-010-024-HAND
x12 Handle
x12 Poignée
x12 Manija

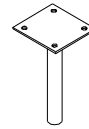

22

RJ038-010-023-LEG2
RJ038-010-024-LEG2
x1 Adjustable Leg
x1 Jambe ajustable
x1 Pierna ajustable

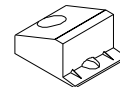

23

RJ038-010-023-FAST
RJ038-010-024-FAST
x6 Angle Fastener
x6 Attache d'angle
x6 Sujetador de ángulo



24

RJ038-010-023-SCR2
RJ038-010-024-SCR2
x6 Screw M3 x 20
x6 Vis M3 x 20
x6 Tornillo M3 x 20



25

RC-ANTI-TIP
x1 Anti-tipping Restraint
x1 Liste des pièces de quincaillerie
antibasculément
x1 Lista del kit de materiales antivuelco



Philips Head screwdriver
(Not included)
Tournevis cruciforme
(Non compris)
Destornillador de estrella
(No incluido)

PARTS LIST / DIAGRAM

PRODUCT NAME / NUMBER(S): J038SL-010A-023 & J038SL-010B-023

J038SL-010A-024 & J038SL-010B-024

DESCRIPTION / DESCRIPCION : Zuma 6 Drawer Double Dresser /
Bureau double 6 tiroirs Zuma /
Cómoda doble de 6 cajones Zuma

STEP 1

ÉTAPE 1

PASO 1

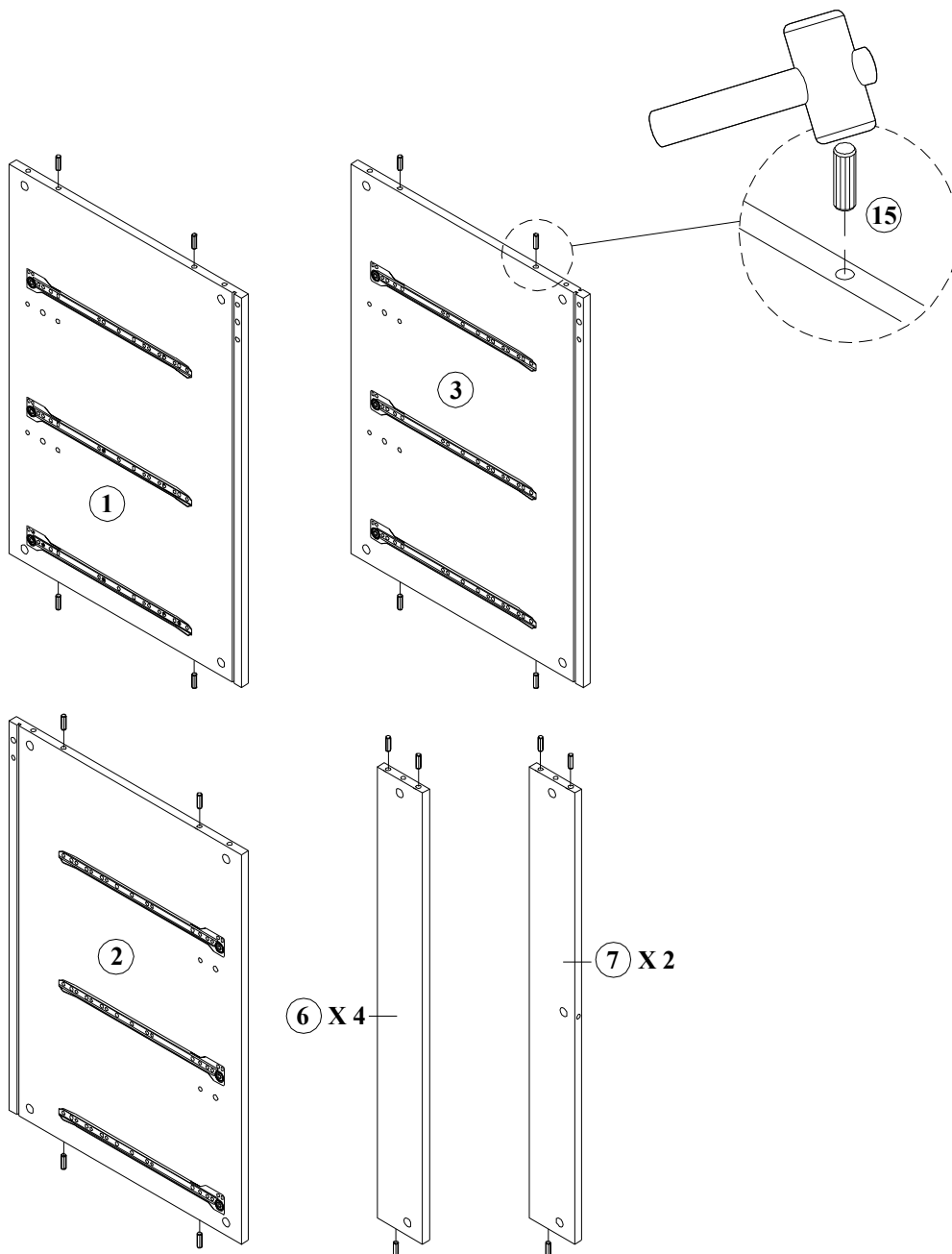
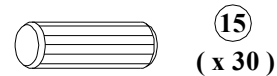

PARTS LIST / DIAGRAM

PRODUCT NAME / NUMBER(S): J038SL-010A-023 & J038SL-010B-023

J038SL-010A-024 & J038SL-010B-024

DESCRIPTION / DESCRIPCION : Zuma 6 Drawer Double Dresser /
Bureau double 6 tiroirs Zuma /
Cómoda doble de 6 cajones Zuma

STEP 2

ÉTAPE 2

PASO 2

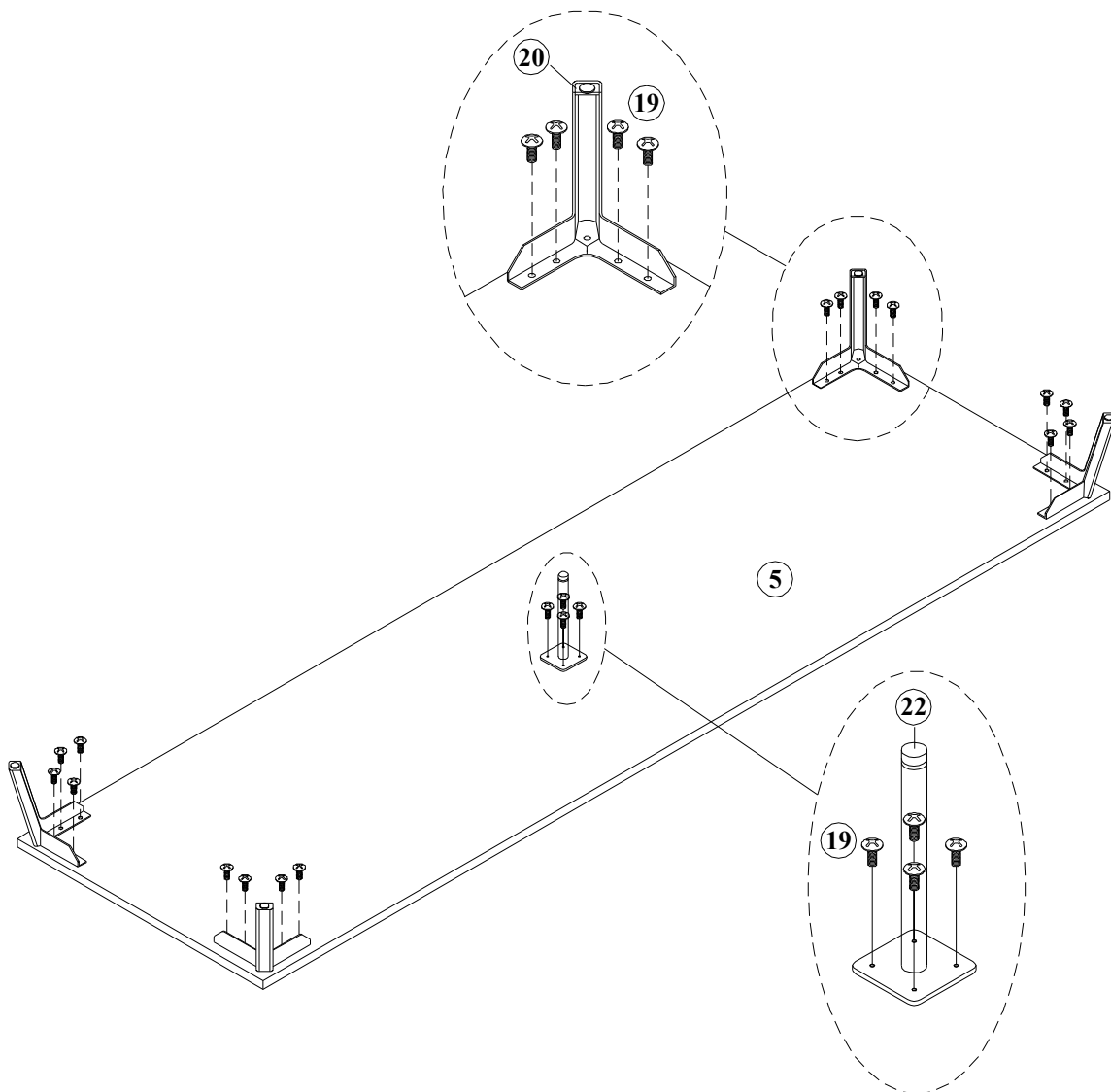
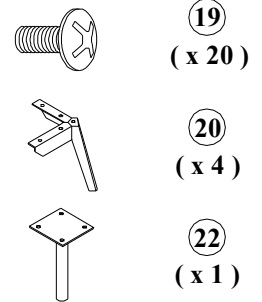

STEP 3

ÉTAPE 3

PASO 3

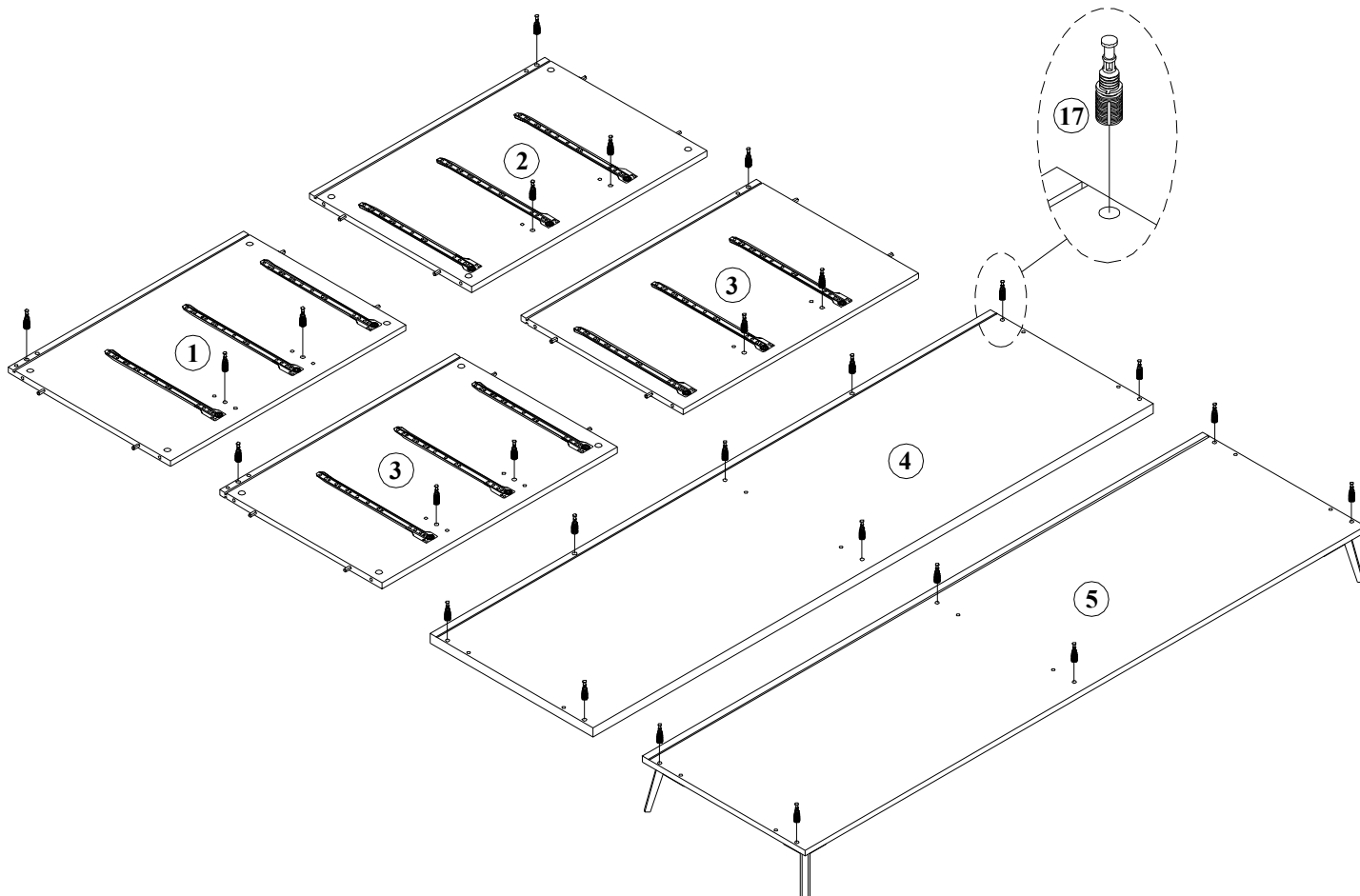
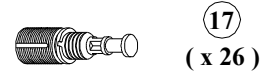
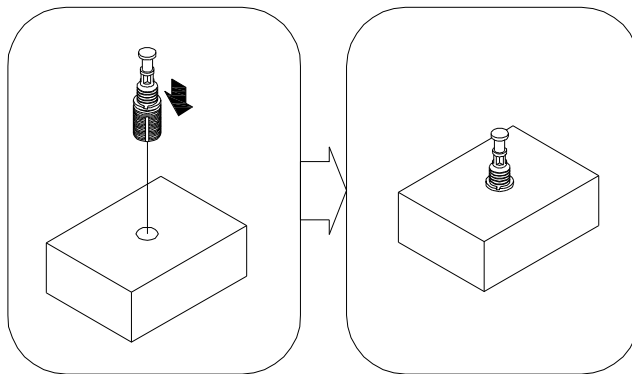

PARTS LIST / DIAGRAM

PRODUCT NAME / NUMBER(S): J038SL-010A-023 & J038SL-010B-023

J038SL-010A-024 & J038SL-010B-024

DESCRIPTION / DESCRIPCION : Zuma 6 Drawer Double Dresser /
Bureau double 6 tiroirs Zuma /
Cómoda doble de 6 cajones Zuma

STEP 4

ÉTAPE 4

PASO 4



18
(x 3)



CAUTION
MISE EN GARDE
PRECAUCIÓN

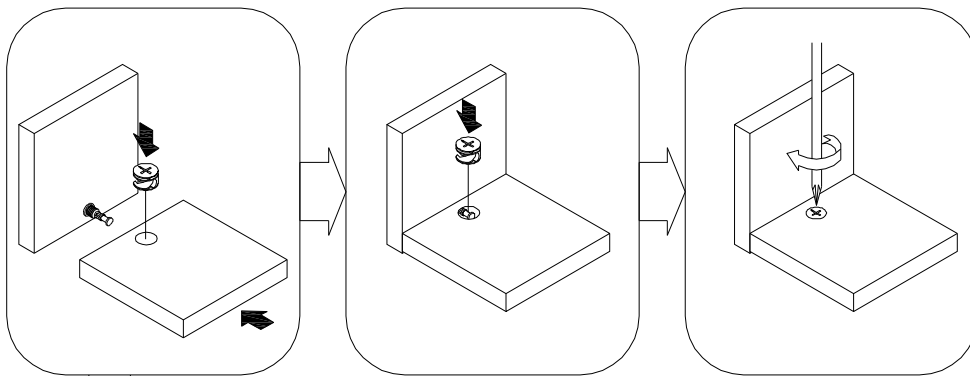
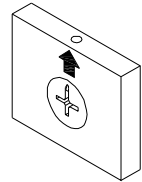

STEP 4.1
ÉTAPE 4.1
PASO 4.1

STEP 4.2
ÉTAPE 4.2
PASO 4.2

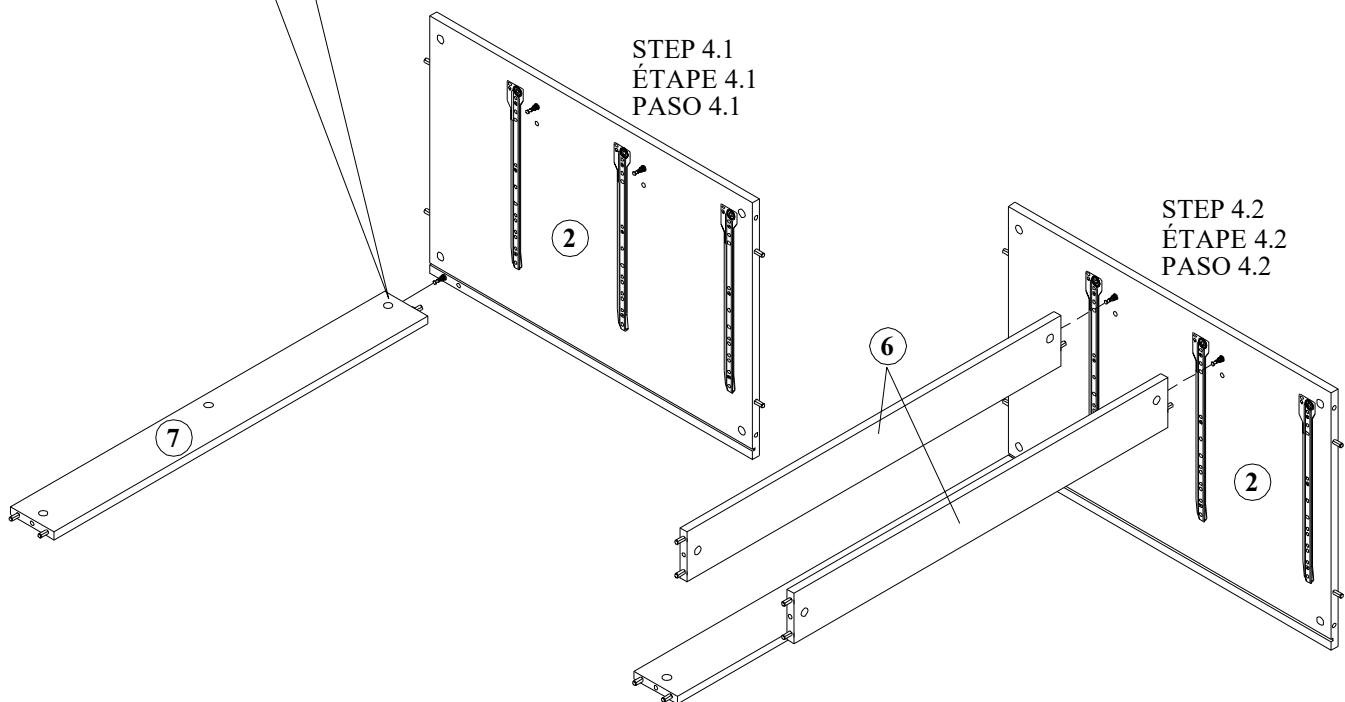

STEP 5

ÉTAPE 5

PASO 5



18
(x 3)



CAUTION
MISE EN GARDE
PRECAUCIÓN

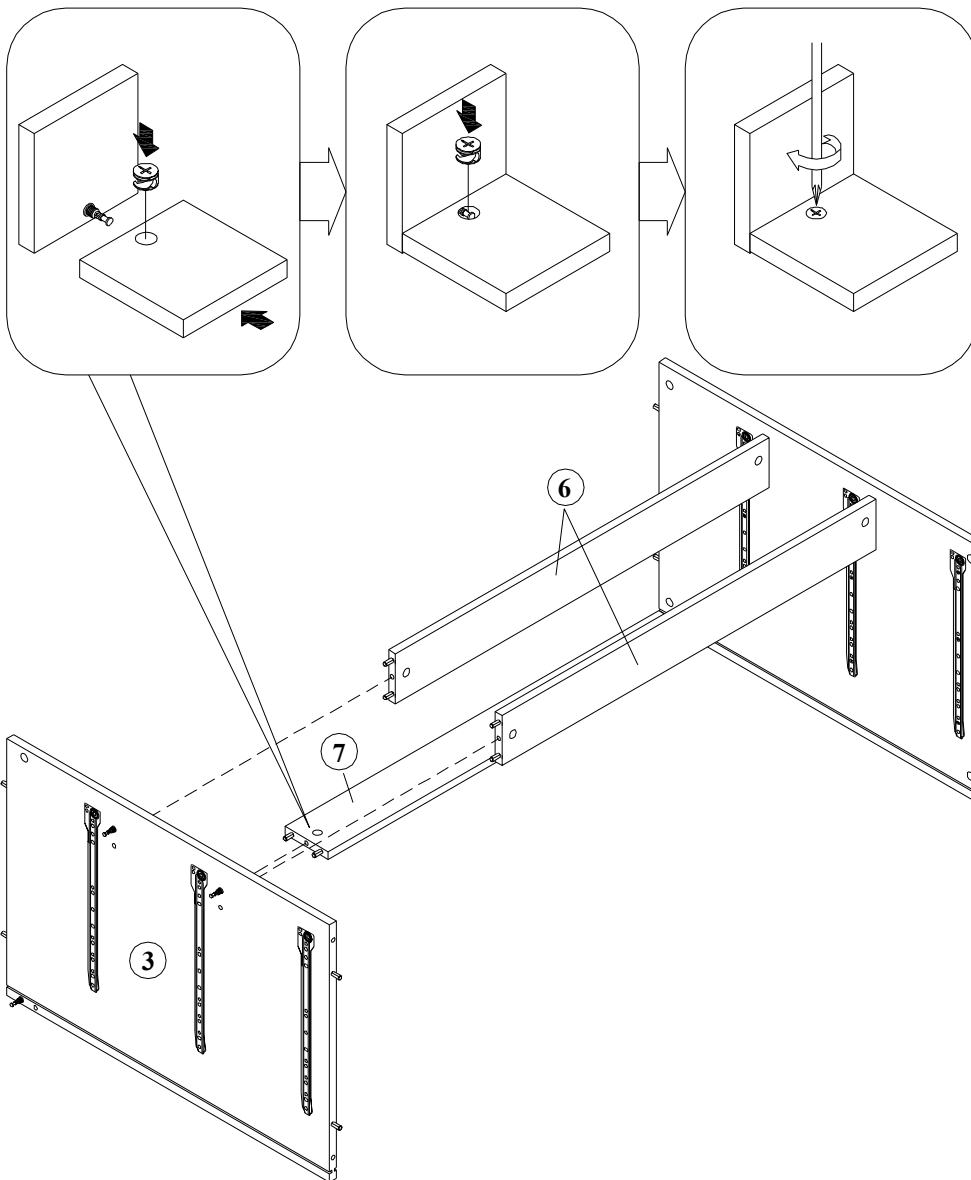
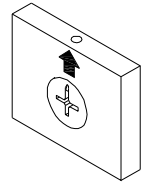

PARTS LIST / DIAGRAM

PRODUCT NAME / NUMBER(S): J038SL-010A-023 & J038SL-010B-023

J038SL-010A-024 & J038SL-010B-024

DESCRIPTION / DESCRIPCION : Zuma 6 Drawer Double Dresser /
Bureau double 6 tiroirs Zuma /
Cómoda doble de 6 cajones Zuma

STEP 6

ÉTAPE 6

PASO 6



18
(x 3)

CAUTION
MISE EN GARDE
PRECAUCIÓN

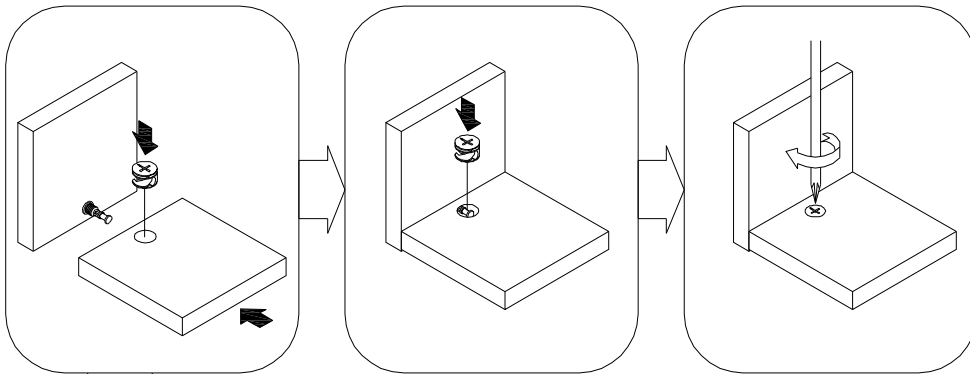
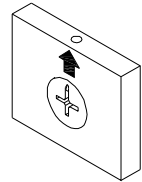

STEP 6.1
ÉTAPE 6.1
PASO 6.1

STEP 6.2
ÉTAPE 6.2
PASO 6.2

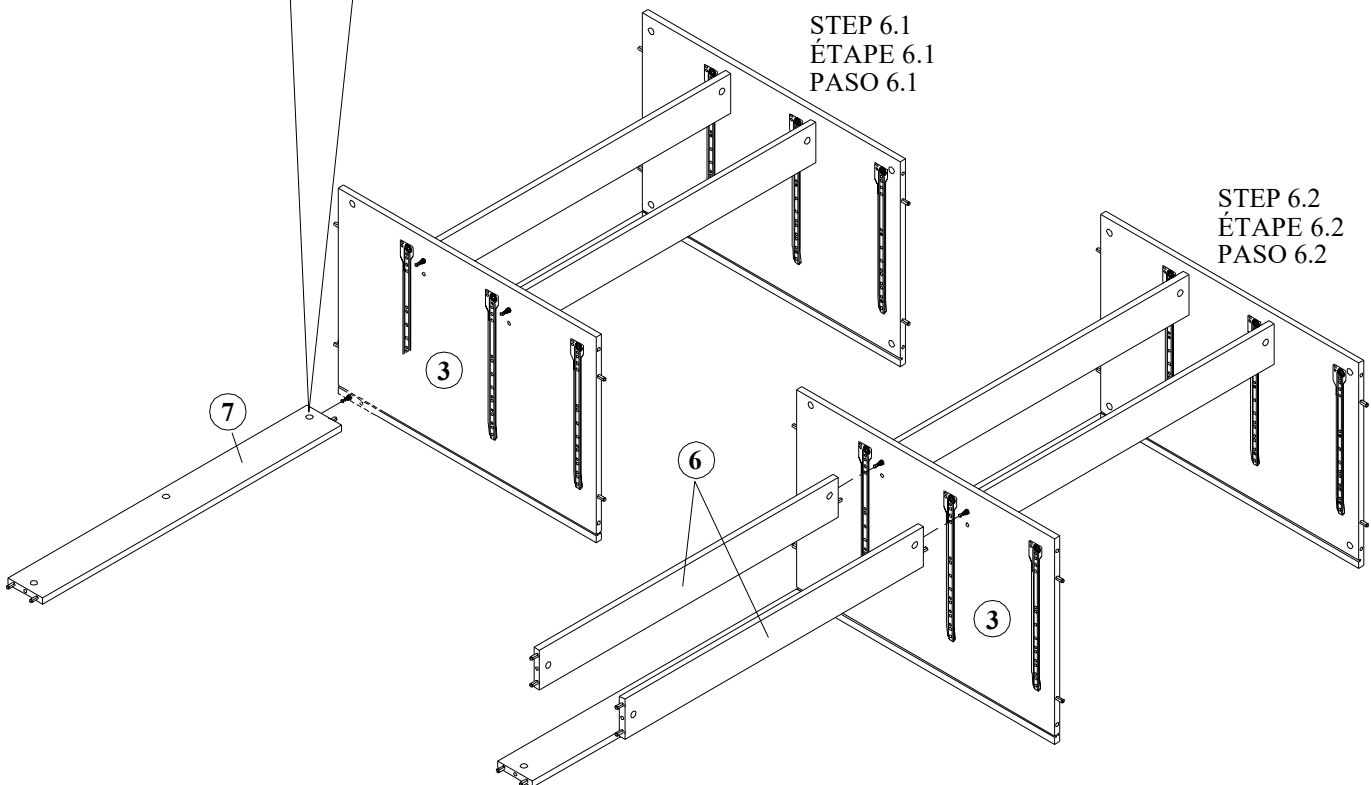

PARTS LIST / DIAGRAM

PRODUCT NAME / NUMBER(S): J038SL-010A-023 & J038SL-010B-023

J038SL-010A-024 & J038SL-010B-024

DESCRIPTION / DESCRIPCION : Zuma 6 Drawer Double Dresser /
Bureau double 6 tiroirs Zuma /
Cómoda doble de 6 cajones Zuma

STEP 7

ÉTAPE 7

PASO 7



18
(x 3)

CAUTION
MISE EN GARDE
PRECAUCIÓN



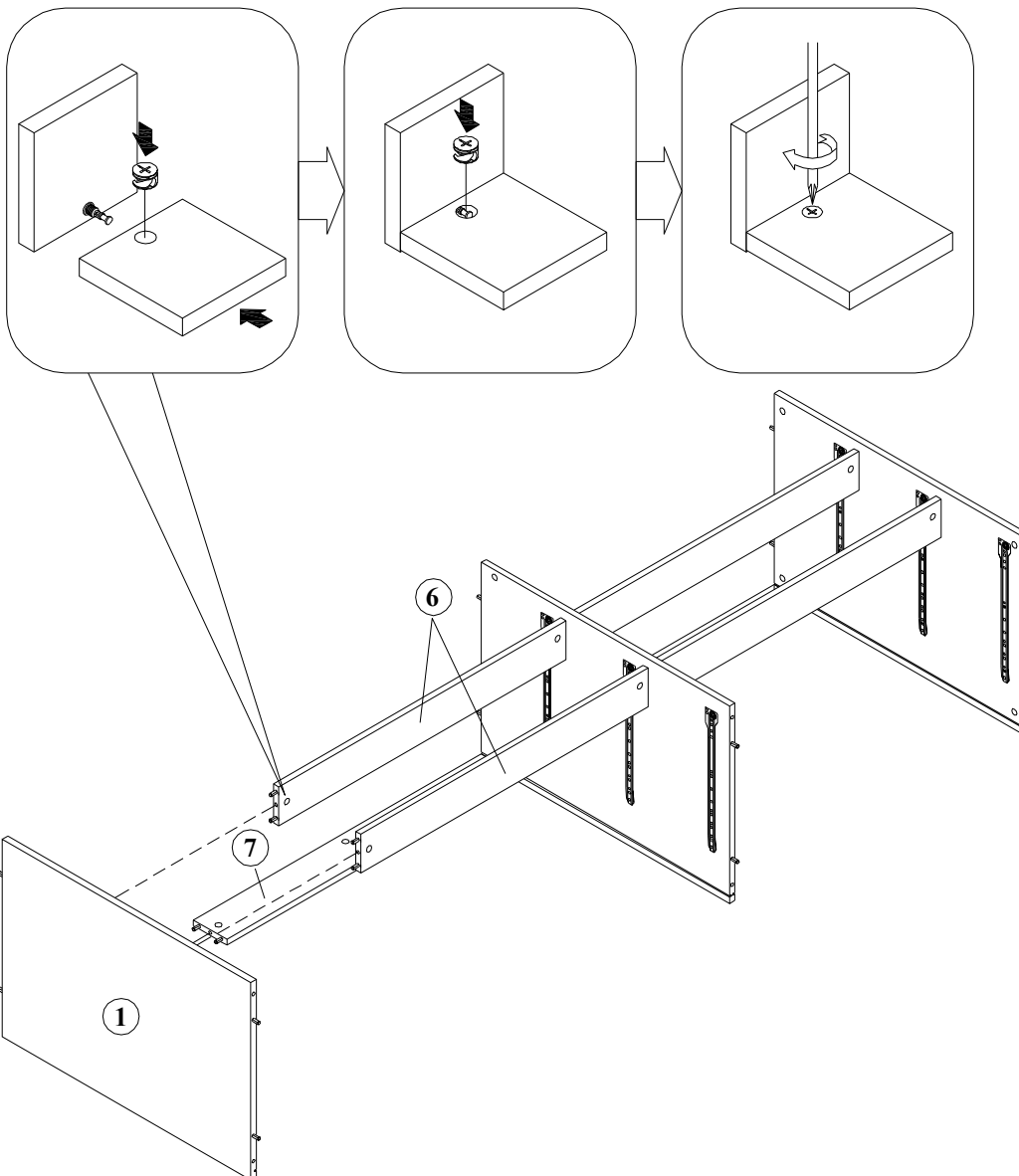

PARTS LIST / DIAGRAM

PRODUCT NAME / NUMBER(S): J038SL-010A-023 & J038SL-010B-023

J038SL-010A-024 & J038SL-010B-024

DESCRIPTION / DESCRIPCION : Zuma 6 Drawer Double Dresser /
Bureau double 6 tiroirs Zuma /
C moda doble de 6 cajones Zuma

STEP 8

 TAPE 8

PASO 8



18
(x 8)

CAUTION
MISE EN GARDE
PRECAUCI N

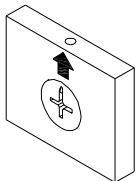
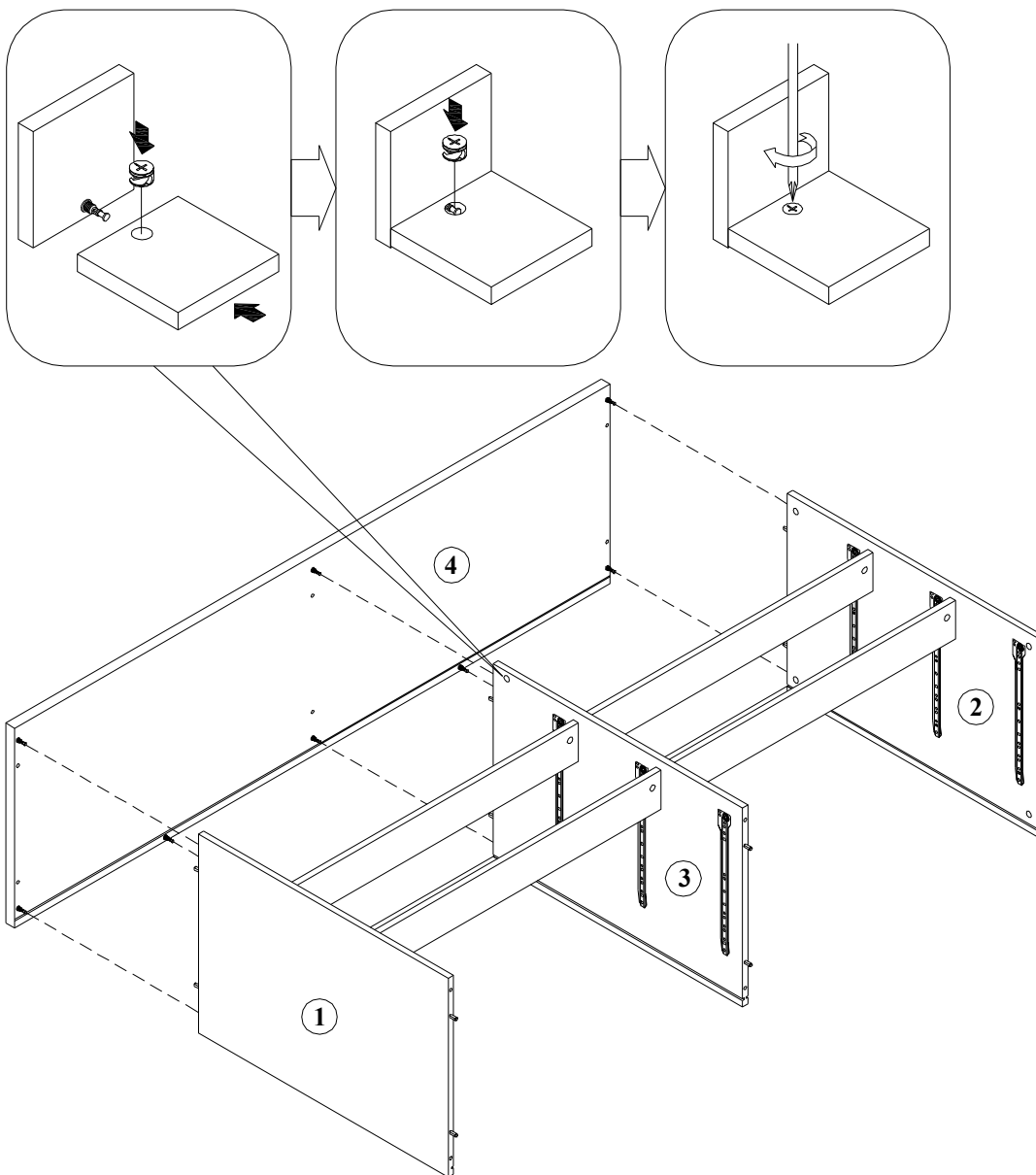
STEP 9

Carefully turn the unit upside down on the protective surface.

ÉTAPE 9

Retournez soigneusement l'appareil à l'envers sur la surface de protection comme indiqué ci-dessous.

PASO 9

Gire con cuidado la unidad boca abajo sobre la superficie protectora como se muestra a continuación.

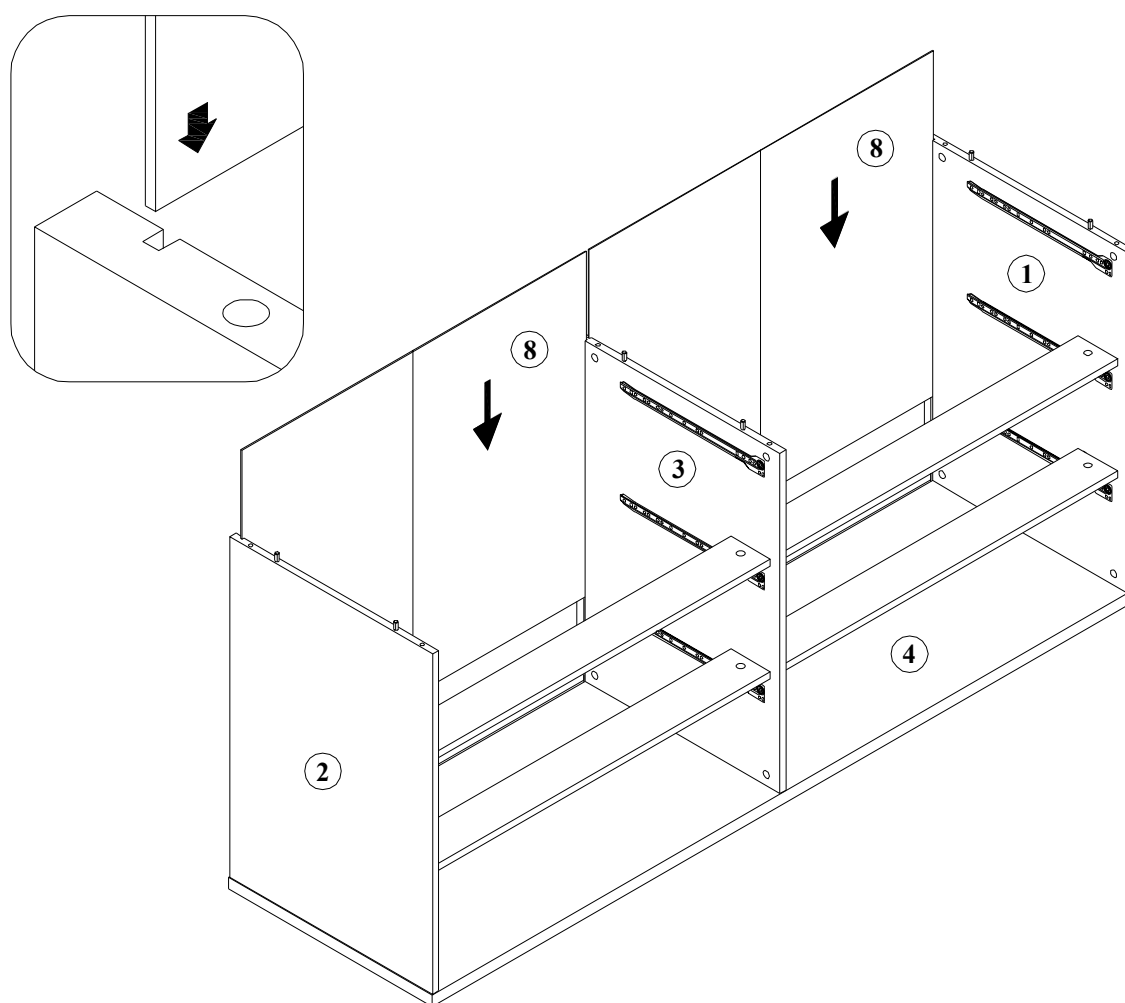

PARTS LIST / DIAGRAM

PRODUCT NAME / NUMBER(S): J038SL-010A-023 & J038SL-010B-023

J038SL-010A-024 & J038SL-010B-024

DESCRIPTION / DESCRIPCION : Zuma 6 Drawer Double Dresser /
Bureau double 6 tiroirs Zuma /
Cómoda doble de 6 cajones Zuma

STEP 10

ÉTAPE 10

PASO 10



18
(x 6)



CAUTION
MISE EN GARDE
PRECAUCIÓN

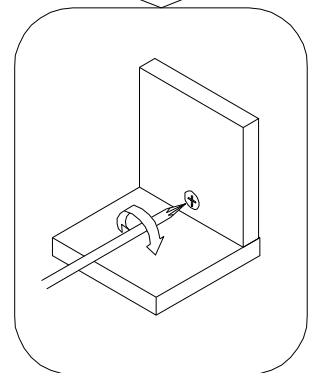
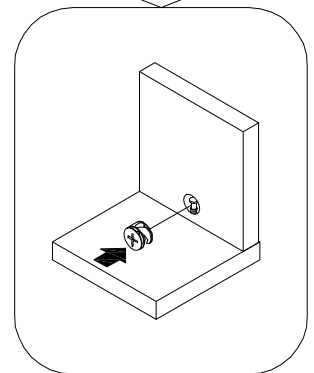
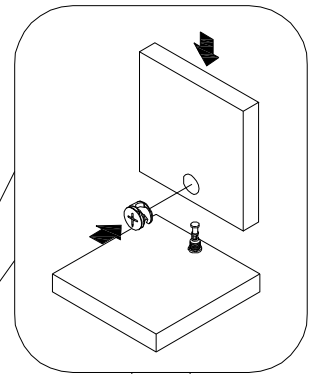
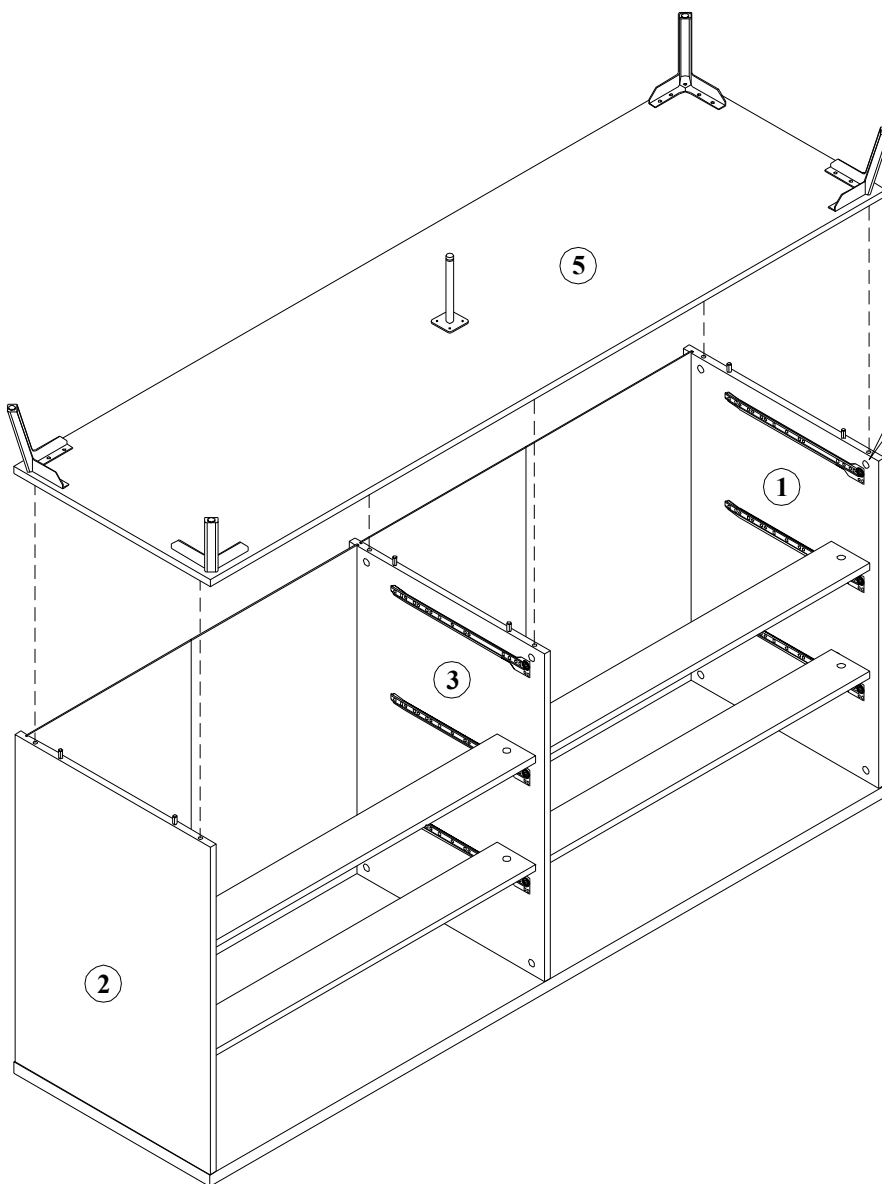
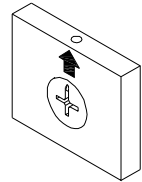

PARTS LIST / DIAGRAM

PRODUCT NAME / NUMBER(S): J038SL-010A-023 & J038SL-010B-023

J038SL-010A-024 & J038SL-010B-024

DESCRIPTION / DESCRIPCION : Zuma 6 Drawer Double Dresser /
Bureau double 6 tiroirs Zuma /
Cómoda doble de 6 cajones Zuma

STEP 11

ÉTAPE 11

PASO 11

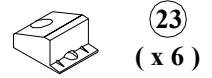

23
(x 6)

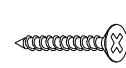

24
(x 6)

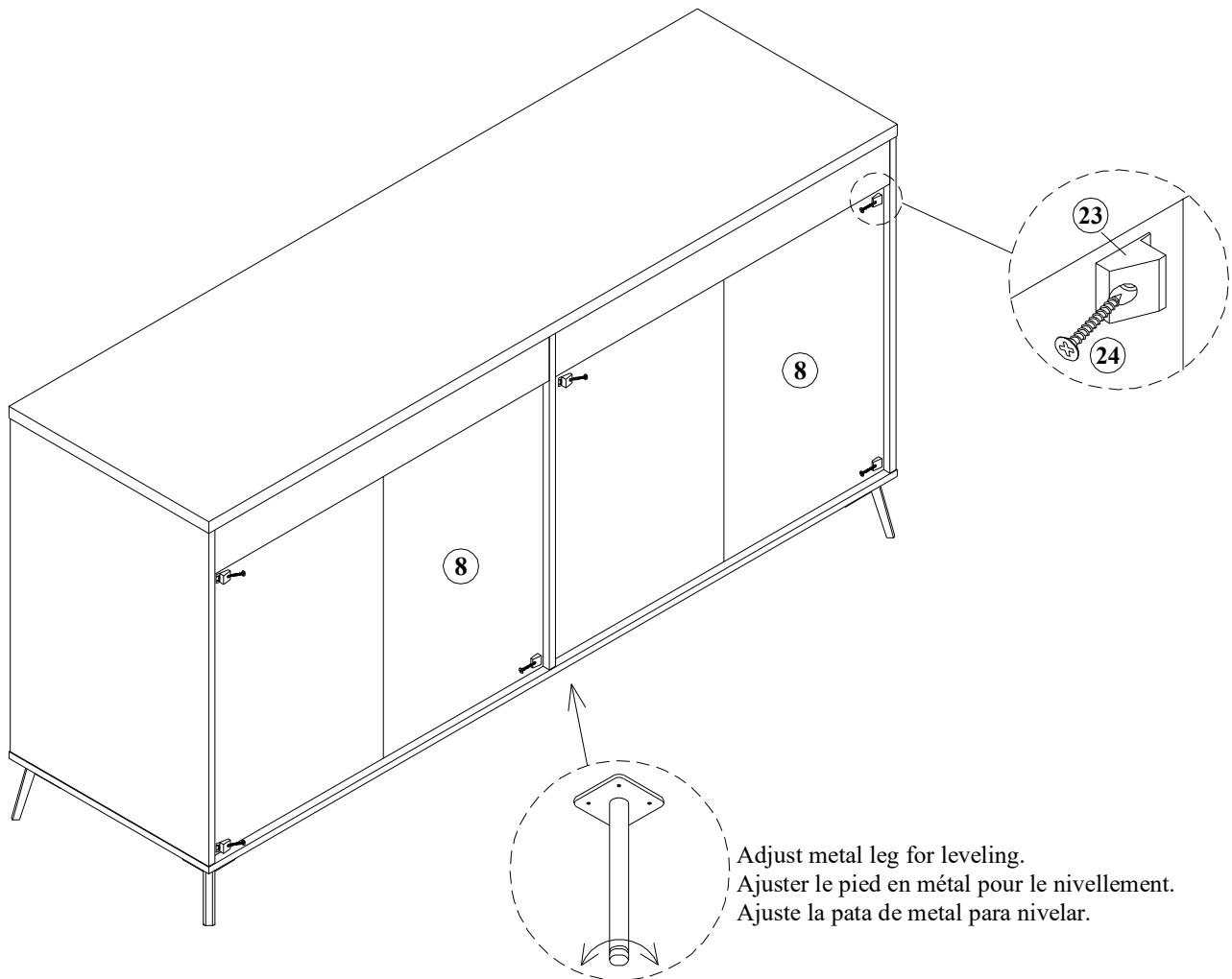

Adjust metal leg for leveling.
Ajuster le pied en métal pour le nivellement.
Ajuste la pata de metal para nivelar.

PARTS LIST / DIAGRAM

PRODUCT NAME / NUMBER(S): J038SL-010A-023 & J038SL-010B-023

J038SL-010A-024 & J038SL-010B-024

DESCRIPTION / DESCRIPCION : Zuma 6 Drawer Double Dresser /
Bureau double 6 tiroirs Zuma /
Cómoda doble de 6 cajones Zuma

STEP 12

ÉTAPE 12

PASO 12

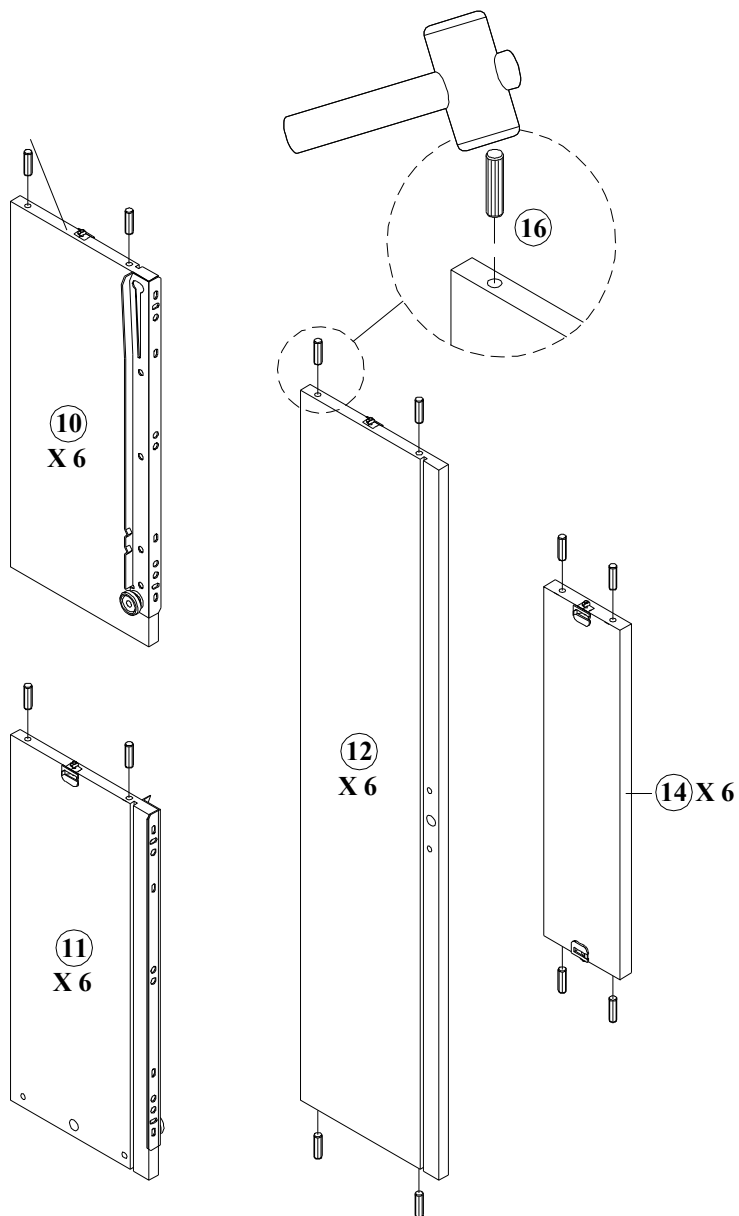
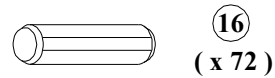

STEP 13

 TAPE 13

PASO 13

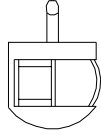
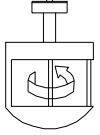
 <p>CAUTION MISE EN GARDE PRECAUCI�N</p>	
 <p>OPEN OUVERT ABIERTO</p>	 <p>LOCK FERMER � CL� BLOQUEAR</p>
<p>PLEASE ENSURE THUMB LOCK IN OPEN POSITION BEFORE ASSEMBLY VEUILLEZ VOUS ASSURER LE VERROUILLAGE DU BOUTON EN POSITION OUVERTE AVANT LE MONTAGE POR FAVOR, ASEG�RESE DEL BLOQUEO DEL PULGAR EN POSICI�N ABIERTA ANTES DEL MONTAJE</p>	

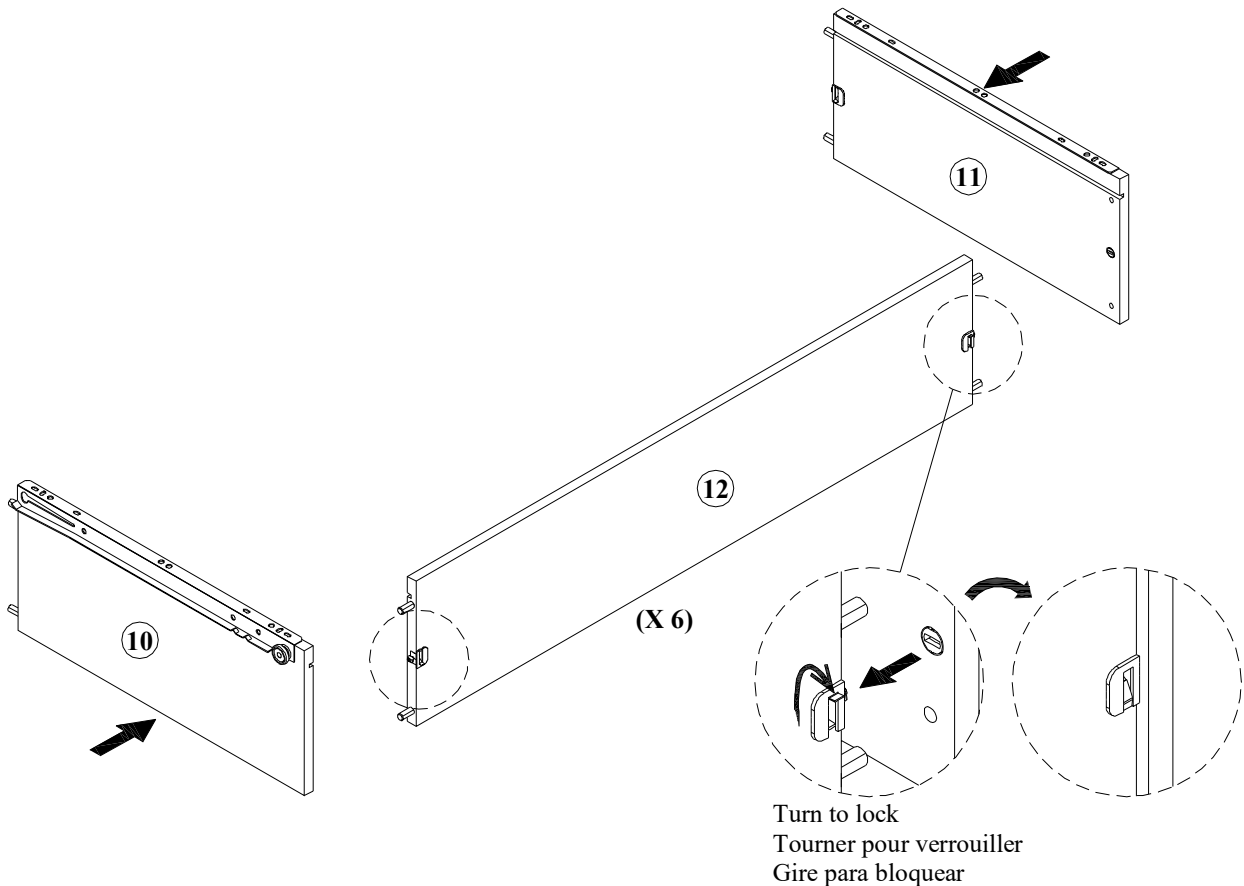

PARTS LIST / DIAGRAM

PRODUCT NAME / NUMBER(S): J038SL-010A-023 & J038SL-010B-023

J038SL-010A-024 & J038SL-010B-024

DESCRIPTION / DESCRIPCION : Zuma 6 Drawer Double Dresser /
Bureau double 6 tiroirs Zuma /
C moda doble de 6 cajones Zuma

STEP 14

 TAPE 14

PASO 14

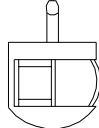
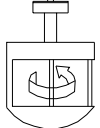
 <p>CAUTION MISE EN GARDE PRECAUCI�N</p>	
 <p>OPEN OUVERT ABIERTO</p>	 <p>LOCK FERMER � CL� BLOQUEAR</p>
<p>PLEASE ENSURE THUMB LOCK IN OPEN POSITION BEFORE ASSEMBLY VEUILLEZ VOUS ASSURER LE VERROUILLAGE DU BOUTON EN POSITION OUVERTE AVANT LE MONTAGE POR FAVOR, ASEG�RESE DEL BLOQUEO DEL PULGAR EN POSICI�N ABIERTA ANTES DEL MONTAJE</p>	

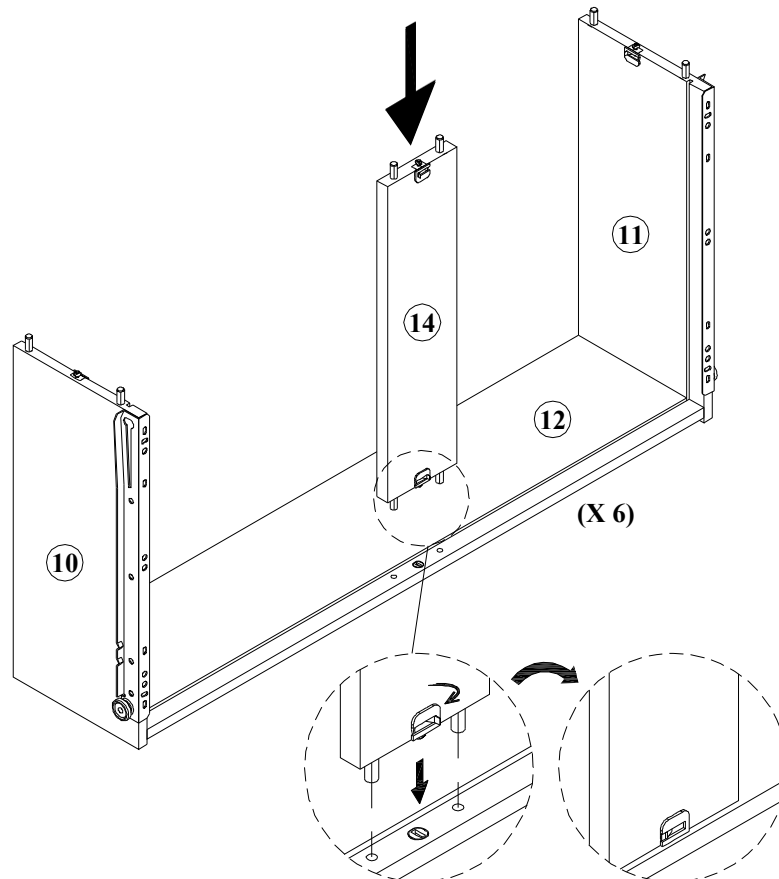

Turn to lock
Tourner pour verrouiller
Gire para bloquear

PARTS LIST / DIAGRAM

PRODUCT NAME / NUMBER(S): J038SL-010A-023 & J038SL-010B-023

J038SL-010A-024 & J038SL-010B-024

DESCRIPTION / DESCRIPCION : Zuma 6 Drawer Double Dresser /
Bureau double 6 tiroirs Zuma /
Cómoda doble de 6 cajones Zuma

STEP 15

ÉTAPE 15

PASO 15

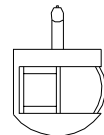
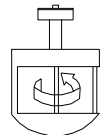
 <p>CAUTION MISE EN GARDE PRECAUCIÓN</p>	
 <p>OPEN OUVERT ABIERTO</p>	 <p>LOCK FERMER À CLÉ BLOQUEAR</p>
<p>PLEASE ENSURE THUMB LOCK IN OPEN POSITION BEFORE ASSEMBLY VEUILLEZ VOUS ASSURER LE VERROUILLAGE DU BOUTON EN POSITION OUVERTE AVANT LE MONTAGE POR FAVOR, ASEGÚRESE DEL BLOQUEO DEL PULGAR EN POSICIÓN ABIERTA ANTES DEL MONTAJE</p>	

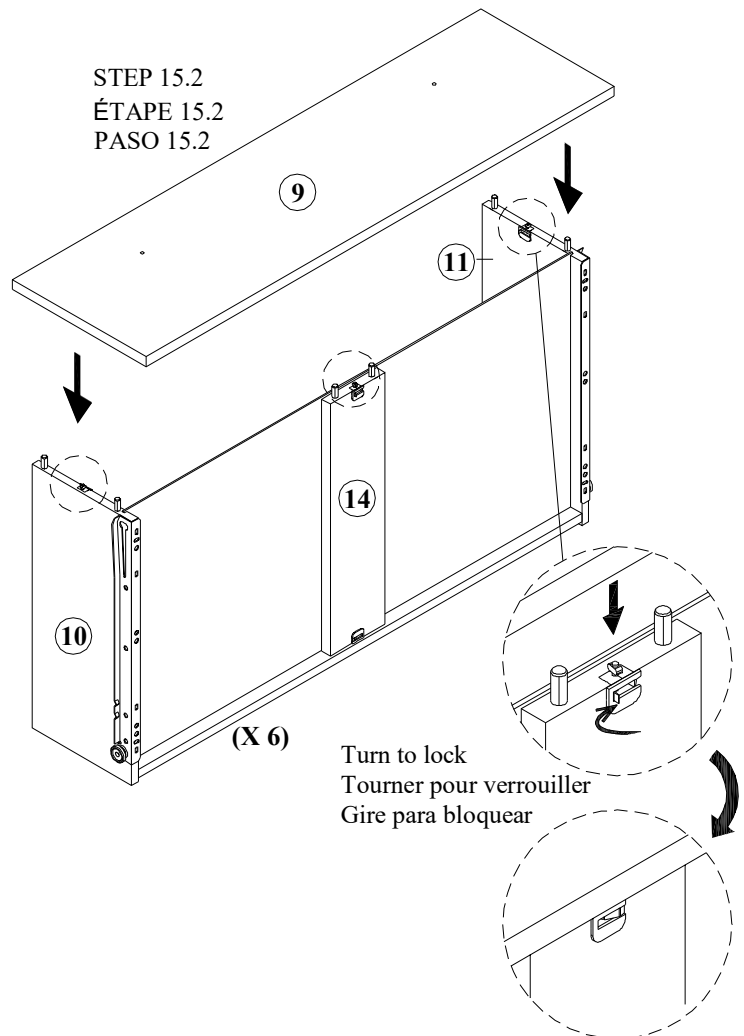
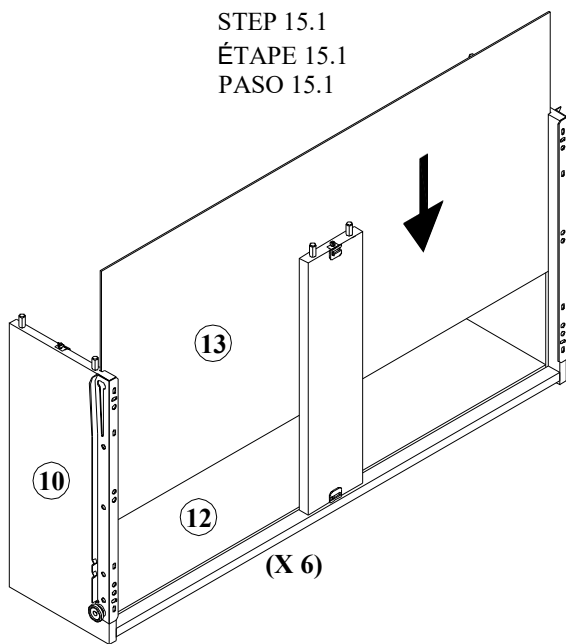

PARTS LIST / DIAGRAM

PRODUCT NAME / NUMBER(S): J038SL-010A-023 & J038SL-010B-023

J038SL-010A-024 & J038SL-010B-024

DESCRIPTION / DESCRIPCION : Zuma 6 Drawer Double Dresser /
Bureau double 6 tiroirs Zuma /
Cómoda doble de 6 cajones Zuma

STEP 16

ÉTAPE 16

PASO 16

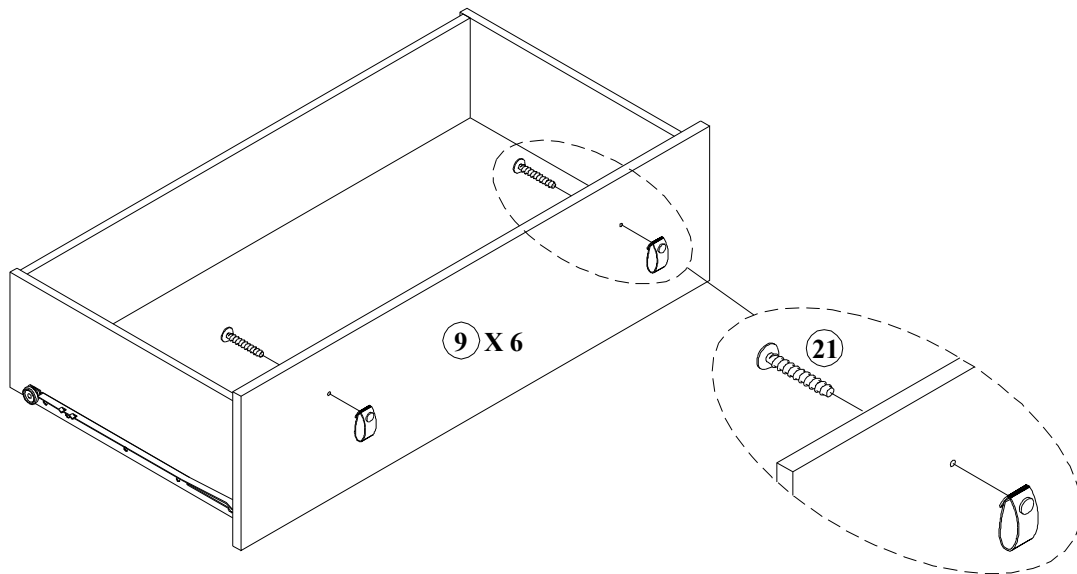
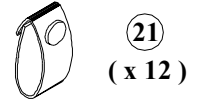

PARTS LIST / DIAGRAM

PRODUCT NAME / NUMBER(S): J038SL-010A-023 & J038SL-010B-023







J038SL-010A-024 & J038SL-010B-024

DESCRIPTION / DESCRIPCION : Zuma 6 Drawer Double Dresser /
Bureau double 6 tiroirs Zuma /
Cómoda doble de 6 cajones Zuma

STEP 17

ÉTAPE 17

PASO 17

▲ WARNING		▲ AVERTISSEMENT		▲ ADVERTENCIA	
	Children have died from furniture tipover. To reduce the risk of furniture tipover :		Des enfants sont morts d'un renversement de meubles. Réduire les risques de renversement de meubles :		Los niños han muerto por la caída de los muebles. Para reducir el riesgo de que los muebles vuelquen :
	<ul style="list-style-type: none"> · ALWAYS install tipover restraint provided. · NEVER put a TV on this product. · NEVER allow children to stand, climb or hang on drawers, doors, or shelves. · NEVER open more than one drawer at a time. · Place heaviest items in the lowest drawers. 		<ul style="list-style-type: none"> · TOUJOURS Installer le dispositif de retenue fourni à cet effet. · NE JAMAIS mettre une télévision sur ce produit · NE JAMAIS laisser un enfant grimper sur les tiroirs, les portes ou les tablettes ou de s'y suspendre. · NE JAMAIS ouvrir plus d'un tiroir à la fois. · Mettre les objets les plus lourds dans les tiroirs du bas. 		<ul style="list-style-type: none"> · SIEMPRE Instale la abrazadera antivuelco proporcionada. · NUNCA ponga un televisor en este producto · NUNCA permita que los niños se suban o se cuelguen sobre los cajones, puertas o repisas. · NUNCA abra más de un cajón a la vez. · Coloque los artículos más pesados en el cajón o repisa de más abajo.
					
This is a permanent label. Do not remove !		Cette étiquette est permanente. Ne pas la retirer!		¡Esta es la etiqueta permanente. No intente removerla!	

The drawer that included tip warning label should be placed on the top right side.

Le tiroir contenant une étiquette d'avertissement de pointe doit être placé sur le côté supérieur droit.

El cajón que incluye la etiqueta de advertencia de punta debe colocarse en la parte superior derecha.

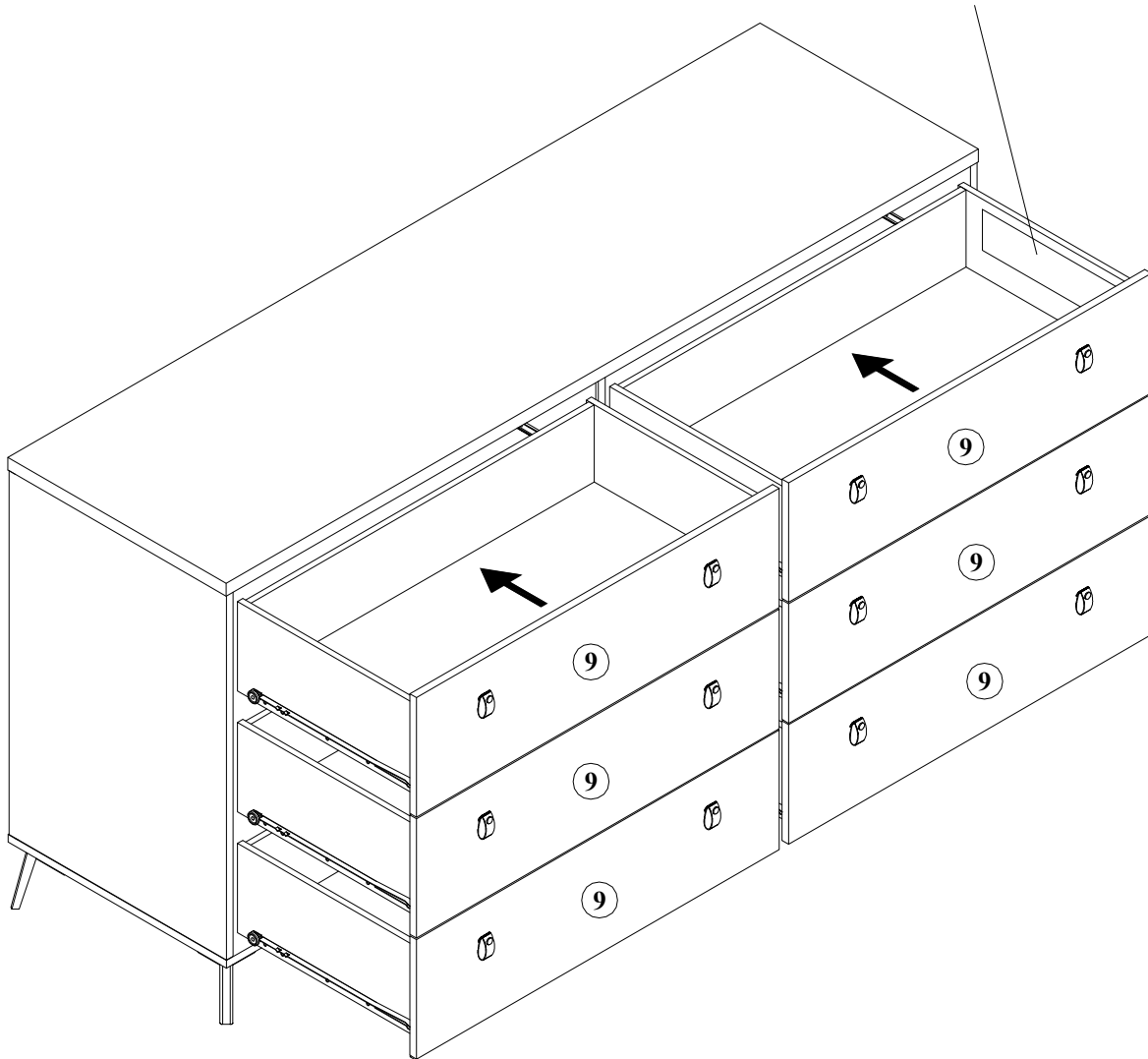

PARTS LIST / DIAGRAM

PRODUCT NAME / NUMBER(S): J038SL-010A-023 & J038SL-010B-023

J038SL-010A-024 & J038SL-010B-024

DESCRIPTION / DESCRIPCION : Zuma 6 Drawer Double Dresser /
Bureau double 6 tiroirs Zuma /
Cómoda doble de 6 cajones Zuma

STEP 18

ÉTAPE 18

PASO 18

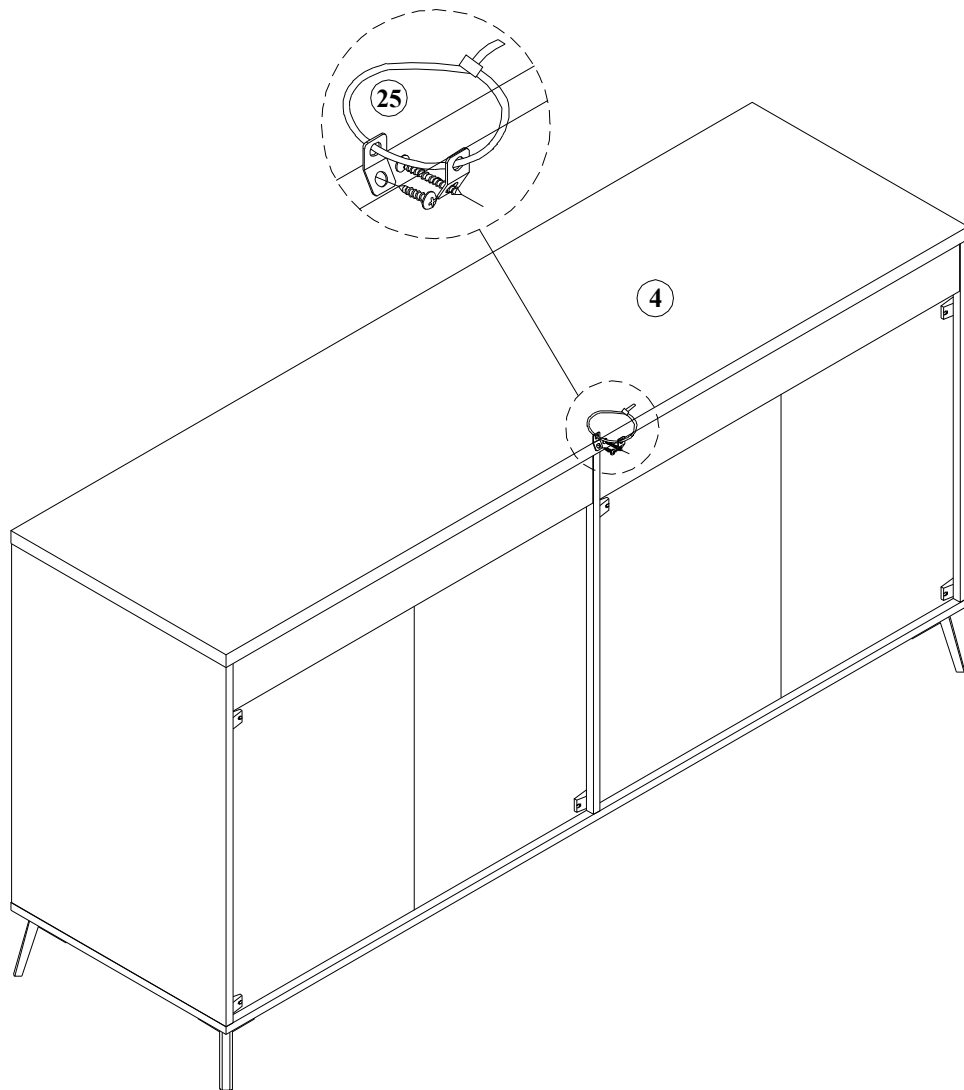
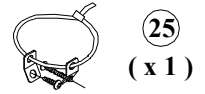

PARTS LIST / DIAGRAM

PRODUCT NAME / NUMBER(S): J038SL-010A-023 & J038SL-010B-023

J038SL-010A-024 & J038SL-010B-024

DESCRIPTION / DESCRIPCION : Zuma 6 Drawer Double Dresser /
Bureau double 6 tiroirs Zuma /
Cómoda doble de 6 cajones Zuma

STEP 19

Completed.

ÉTAPE 19

Terminé.

PASO 19

Terminado.

