

PARTS LIST / LISTE DES PIÈCES / LISTA DE PIEZAS

ITEM / NO D' ARTICLE / ARTICULO : J010-010A/ B - 3000 & 3001

DESCRIPTION / DESCRIPCIÓN: DRESSER / COMMODE / TOCADOR

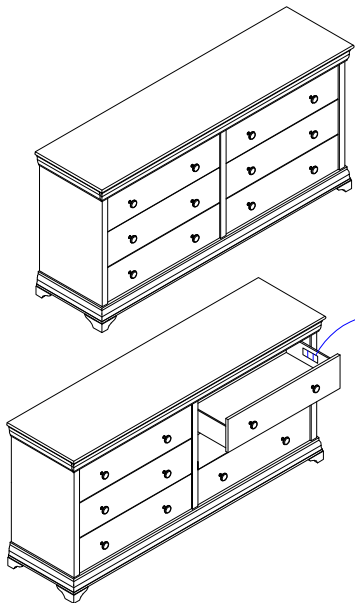

⚠ WARNING	⚠ AVERTISSEMENT	⚠ ADVERTENCIA
 <p>Children have died from furniture tipover. To reduce the risk of furniture tipover :</p> <ul style="list-style-type: none"> • ALWAYS install tipover restraint provided. • NEVER put a TV on this product. • NEVER allow children to stand, climb or hang on drawers, doors, or shelves. • NEVER open more than one drawer at a time. • Place heaviest items in the lowest drawers. 	 <p>Des enfants sont morts d'un renversement de meubles. Réduire les risques de renversement de meubles :</p> <ul style="list-style-type: none"> • TOUJOURS installer le dispositif de retenue fourni à cet effet. • NE JAMAIS mettre une télévision sur ce produit. • NE JAMAIS laisser un enfant grimper sur les tiroirs, les portes ou les tablettes ou de s'y suspendre. • NE JAMAIS ouvrir plus d'un tiroir à la fois. • Mettre les objets les plus lourds dans les tiroirs du bas. 	<p>Los niños han muerto por la caída de los muebles. Para reducir el riesgo de que los muebles vuelquen :</p> <ul style="list-style-type: none"> • SIEMPRE instale la abrazadera antivuelco proporcionada. • NUNCA ponga un televisor en este producto • NUNCA permita que los niños se suban o se cuelguen sobre los cajones, puertas o repisas. • NUNCA abra más de un cajón a la vez. • Coloque los artículos más pesados en el cajón o repisa de más abajo.
<p><i>This is a permanent label. Do not remove !</i></p>	<p><i>Cette étiquette est permanente. Ne pas la retirer!</i></p>	<p><i>¡Esta es la etiqueta permanente. No intente removerla!</i></p>

The drawer that included tip warning label should be placed on the top right side
 Le tiroir contenant une étiquette d'avertissement de pointe doit être placé sur le côté supérieur droit
 El cajón que incluye la etiqueta de advertencia de punta debe colocarse en la parte superior derecha

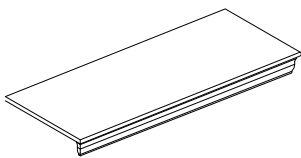

A

RJ010-010-3000-TOP
 # RJ010-010-3001-TOP
 x1 Top panel
 x1 Panneau supérieur
 x1 Panel superior

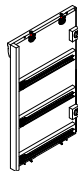

B

RJ010-010-3000-LSF
 # RJ010-010-3001-LSF
 x1 Left end panel
 x1 Panneau gauche
 x1 Panel del extremo izquierdo

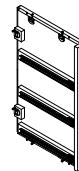

C

RJ010-010-3000-RSF
 # RJ010-010-3001-RSF
 x1 Right end panel
 x1 Panneau droit
 x1 Panel del extremo derecho

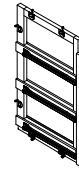

D

RJ010-010-3000-CEF
 # RJ010-010-3001-CEF
 x1 Center frame
 x1 Partie centrale
 x1 Marco central

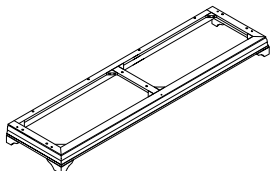

E

RJ010-010-3000-BOF
 # RJ010-010-3001-BOF
 x1 Bottom frame
 x1 Cadre inférieur
 x1 Marco inferior

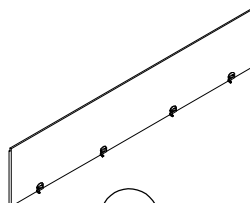

F

RJ010-010-3000-BP1
 # RJ010-010-3001-BP1
 x1 Back panel 1
 x1 Panneau arrière 1
 x1 Panel posterior 1

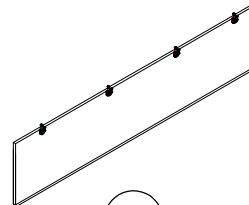

G

RJ010-010-3000-BP2
 # RJ010-010-3001-BP2
 x1 Back panel 2
 x1 Panneau arrière 2
 x1 Panel posterior 2

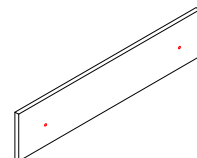

H

RJ010-010-3000-DFP
 # RJ010-010-3001-DFP
 x6 Drawer front panel
 x6 Panneau avant du tiroir
 x6 Panel frontal del cajón

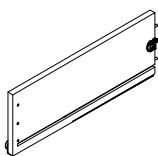

I

RJ010-010-3000-RDP
 # RJ010-010-3001-RDP
 x6 Right drawer panel
 x6 Panneau de tiroir droit
 x6 Panel del cajón derecho

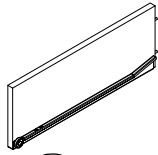

J

RJ010-010-3000-LDP
 # RJ010-010-3001-LDP
 x6 Left drawer panel
 x6 Panneau de tiroir gauche
 x6 Panel de cajón izquierdo

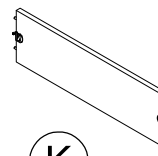

K

RJ010-010-3000-DBP
 # RJ010-010-3001-DBP
 x6 Drawer back panel
 x6 Panneau arrière du tiroir
 x6 Panel trasero del cajón

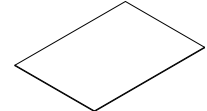

L

RJ010-010-3000-DOP
 # RJ010-010-3001-DOP
 x6 Drawer bottom panel
 x6 Panneau inférieur du tiroir
 x6 Panel inferior del cajón



M

RJ010-010-3000-DSP
 # RJ010-010-3001-DSP
 x6 Drawer support Panel
 x6 Panneau de support de tiroir
 x6 Panel de soporte del cajón

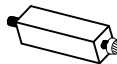

N

RJ010-010-3000-CSL
 # RJ010-010-3001-CSL
 x1 Center support leg
 x1 Pattes centerles
 x1 Patras centerles



O

RJ010-010-3000-KNO
 # RJ010-010-3001-KNO
 x12 Knob + Screw 5/32x18mm
 x12 Tirer + Vis 5/32x18mm
 x12 Tire + Tornillo 5/32x18mm



P

RC-ANTI-TIP
 x1 Anti-tipping Restraint
 x1 Systeme antibasculement
 x1 Control para evitar vuelcos

ASSEMBLY INTRUCTIONS / NOTICE DE MONTAGE / INSTRUCCIONES DE MONTAJE

ITEM / NO D' ARTICLE / ARTICULO : J010-010A/ B - 3000 & 3001

DESCRIPTION / DESCRIPCIÓN: DRESSER / COMMODE / TOCADOR

STEP 1 ÉTAPE 1 PASO 1

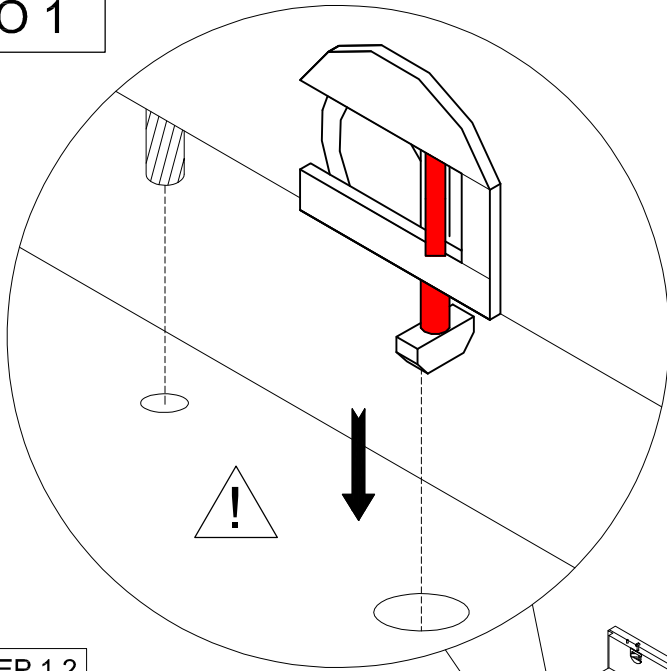

CAUTION
MISE EN GARDE
PRECAUCIÓN

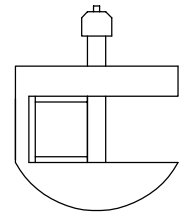

OPEN / OUVERT
ABIERTO

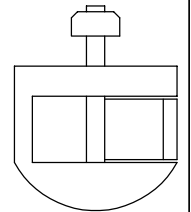

LOCK / VERROUILLÉ
BLOQUEAR

PLEASE ENSURE THUMB LOCK IN OPEN POSITION BEFORE ASSEMBLY.
VEUILLEZ VOUS ASSURER LE VERROUILLAGE DU BOUTON EN POSITION OUVERTE AVANT LE MONTAGE.
POR FAVOR, ASEGÚRESE DEL BLOQUEO DEL PULGAR EN POSICIÓN ABIERTA ANTES DEL MONTAJE.

STEP 1.2

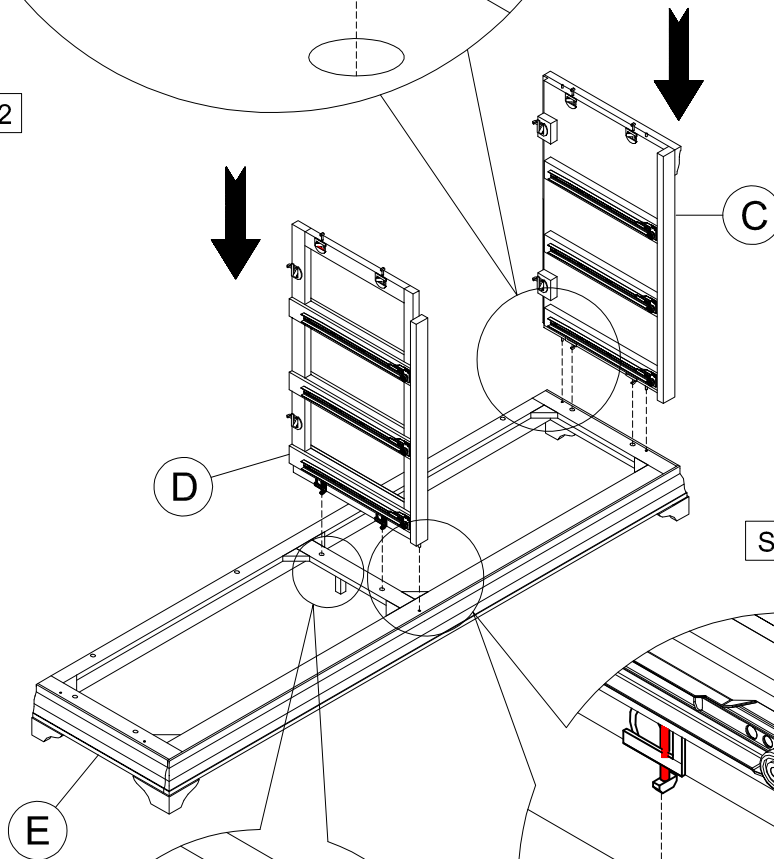

STEP 1.3

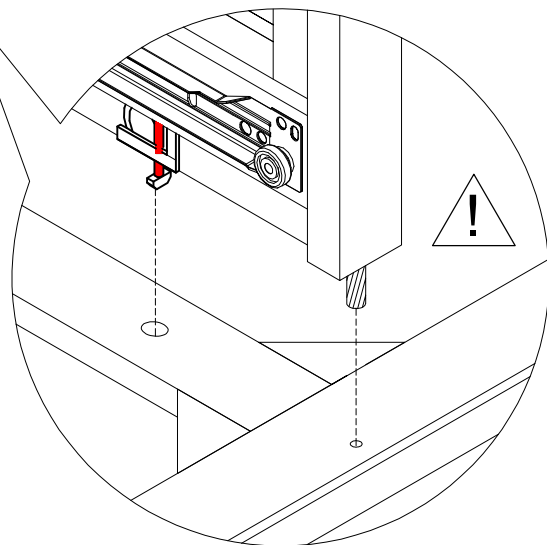

STEP 1.1

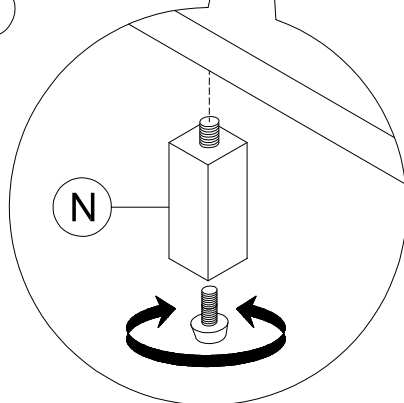

ASSEMBLY INTRUCTIONS / NOTICE DE MONTAGE / INSTRUCCIONES DE MONTAJE

ITEM / NO D' ARTICLE / ARTICULO : J010-010A/ B - 3000 & 3001

DESCRIPTION / DESCRIPCIÓN: DRESSER / COMMODE / TOCADOR

**STEP 2
ÉTAPE 2
PASO 2**



**CAUTION
MISE EN GARDE
PRECAUCIÓN**

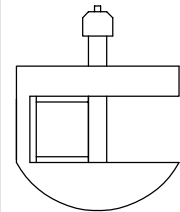

**OPEN / OUVERT
ABIERTO**

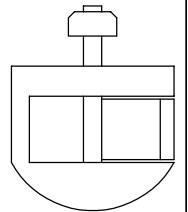

**LOCK / VERROUILLÉ
BLOQUEAR**

PLEASE ENSURE THUMB LOCK IN OPEN POSITION BEFORE ASSEMBLY.
VEUILLEZ VOUS ASSURER LE VERROUILLAGE DU BOUTON EN POSITION OUVERTE AVANT LE MONTAGE.
POR FAVOR, ASEGÚRESE DEL BLOQUEO DEL PULGAR EN POSICIÓN ABIERTA ANTES DEL MONTAJE.

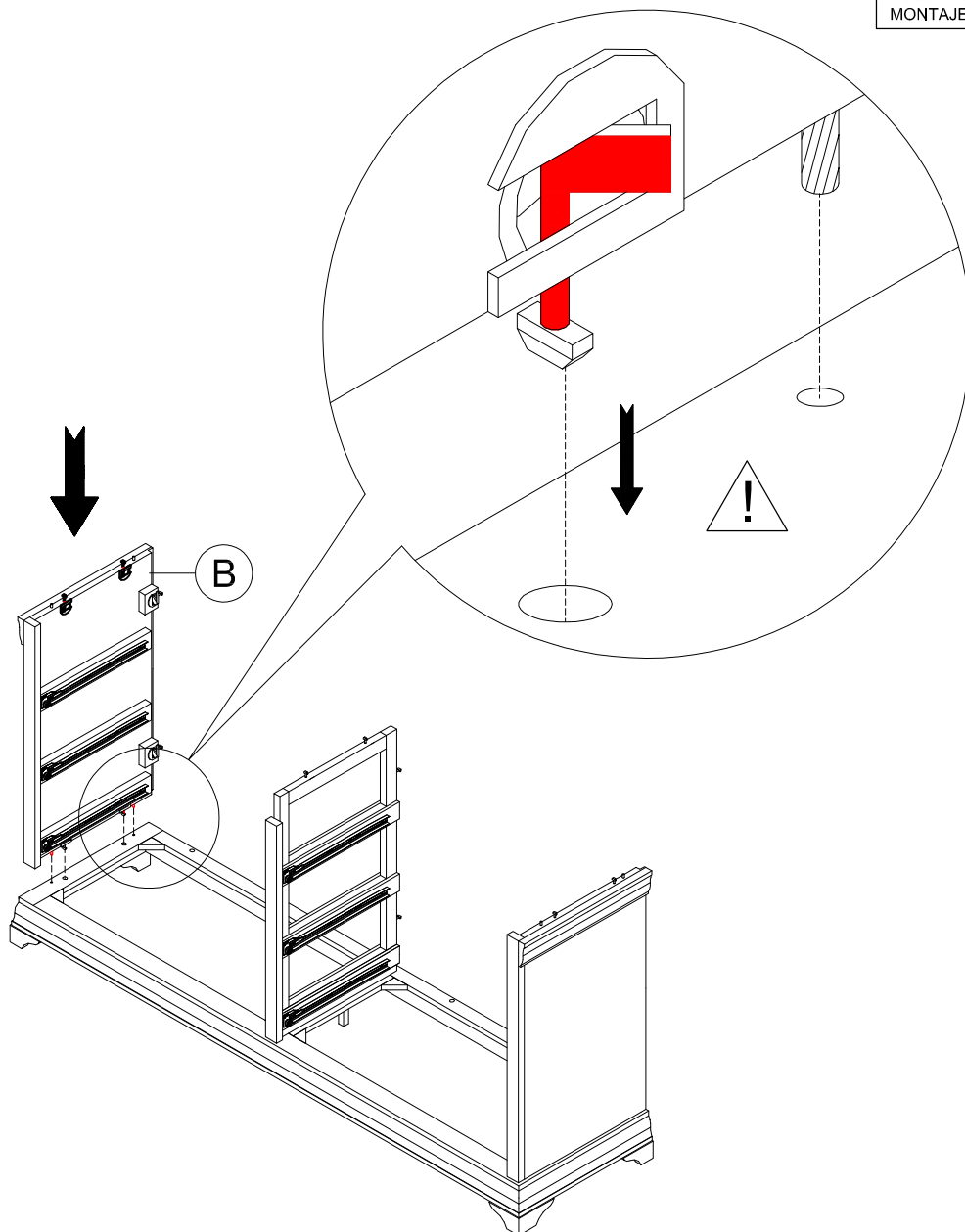

ASSEMBLY INSTRUCTIONS / NOTICE DE MONTAGE / INSTRUCCIONES DE MONTAJE

ITEM / NO D' ARTICLE / ARTICULO : J010-010A/ B - 3000 & 3001

DESCRIPTION / DESCRIPCIÓN: DRESSER / COMMODE / TOCADOR

STEP 3 ÉTAPE 3 PASO 3



CAUTION
MISE EN GARDE
PRECAUCIÓN

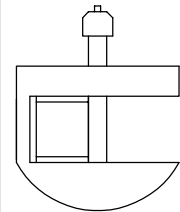

OPEN / OUVERT
ABIERTO

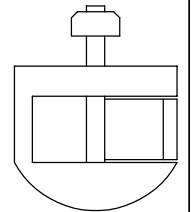

LOCK / VERROUILLÉ
BLOQUEAR

PLEASE ENSURE THUMB LOCK IN OPEN POSITION BEFORE ASSEMBLY.
VEUILLEZ VOUS ASSURER LE VERROUILLAGE DU BOUTON EN POSITION OUVERTE AVANT LE MONTAGE.
POR FAVOR, ASEGÚRESE DEL BLOQUEO DEL PULGAR EN POSICIÓN ABIERTA ANTES DEL MONTAJE.

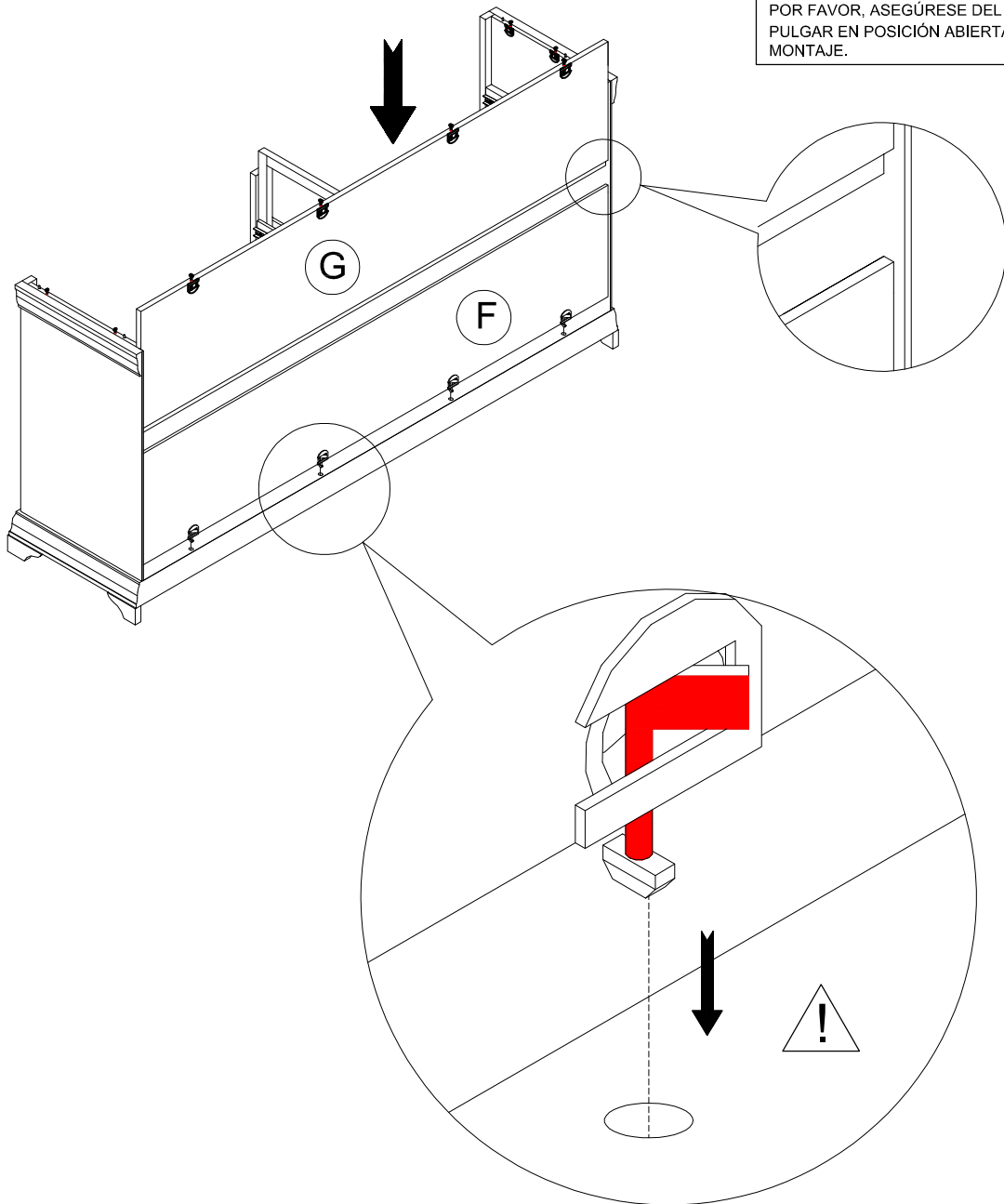

ASSEMBLY INTRUCTIONS / NOTICE DE MONTAGE / INSTRUCCIONES DE MONTAJE

ITEM / NO D' ARTICLE / ARTICULO : J010-010A/ B - 3000 & 3001

DESCRIPTION / DESCRIPCIÓN: DRESSER / COMMODE / TOCADOR

**STEP 4
ÉTAPE 4
PASO 4**

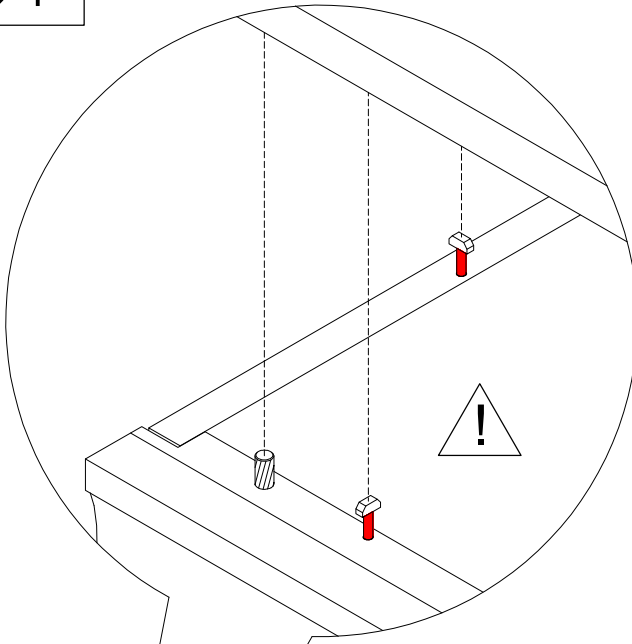

STEP 4.1



A

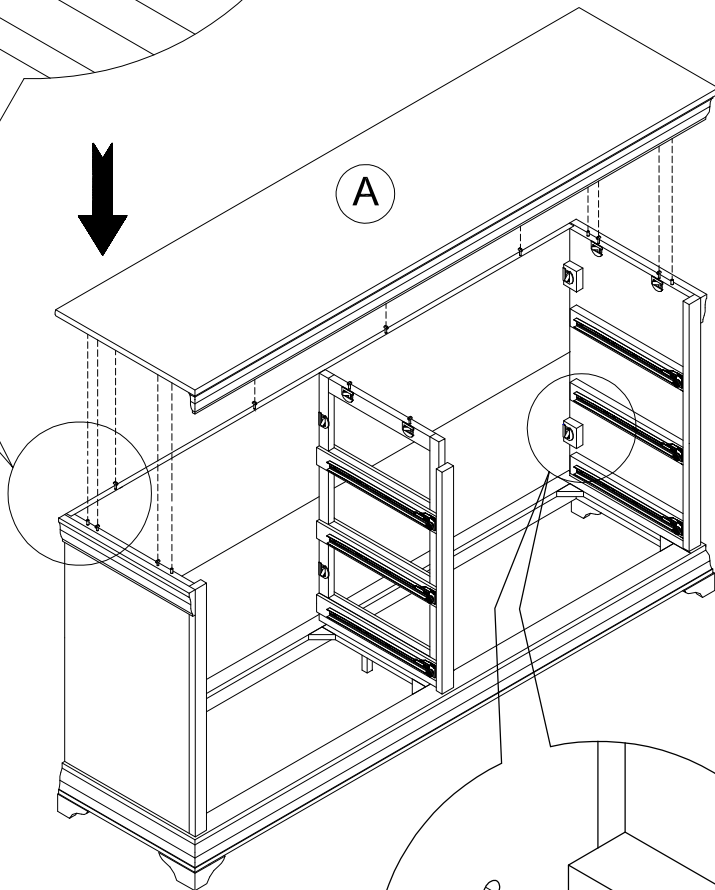

STEP 4.2

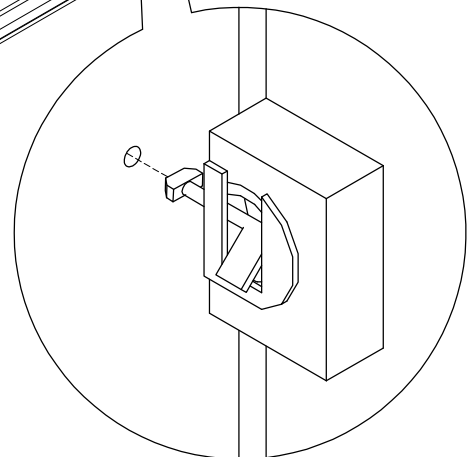

**CAUTION
MISE EN GARDE
PRECAUCIÓN**

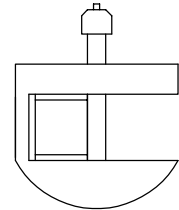

**OPEN / OUVERT
ABIERTO**

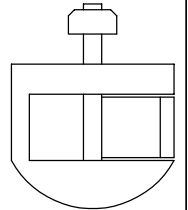

**LOCK / VERROUILLÉ
BLOQUEAR**

PLEASE ENSURE THUMB LOCK IN OPEN POSITION BEFORE ASSEMBLY.
VEUILLEZ VOUS ASSURER LE VERROUILLAGE DU BOUTON EN POSITION OUVERTE AVANT LE MONTAGE.
POR FAVOR, ASEGÚRESE DEL BLOQUEO DEL PULGAR EN POSICIÓN ABIERTA ANTES DEL MONTAJE.

ASSEMBLY INSTRUCTIONS / NOTICE DE MONTAGE / INSTRUCCIONES DE MONTAJE

ITEM / NO D' ARTICLE / ARTICULO : J010-010A/ B - 3000 & 3001

DESCRIPTION / DESCRIPCIÓN: DRESSER / COMMODE / TOCADOR

STEP 5 ÉTAPE 5 PASO 5



CAUTION
MISE EN GARDE
PRECAUCIÓN

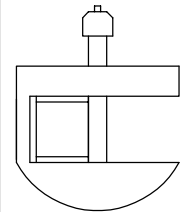

OPEN / OUVERT
ABIERTO

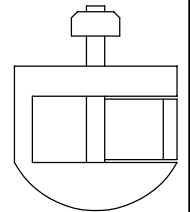

LOCK / VERROUILLÉ
BLOQUEAR

PLEASE ENSURE THUMB LOCK IN OPEN POSITION BEFORE ASSEMBLY.
VEUILLEZ VOUS ASSURER LE VERROUILLAGE DU BOUTON EN POSITION OUVERTE AVANT LE MONTAGE.
POR FAVOR, ASEGÚRESE DEL BLOQUEO DEL PULGAR EN POSICIÓN ABIERTA ANTES DEL MONTAJE.

STEP 5.1

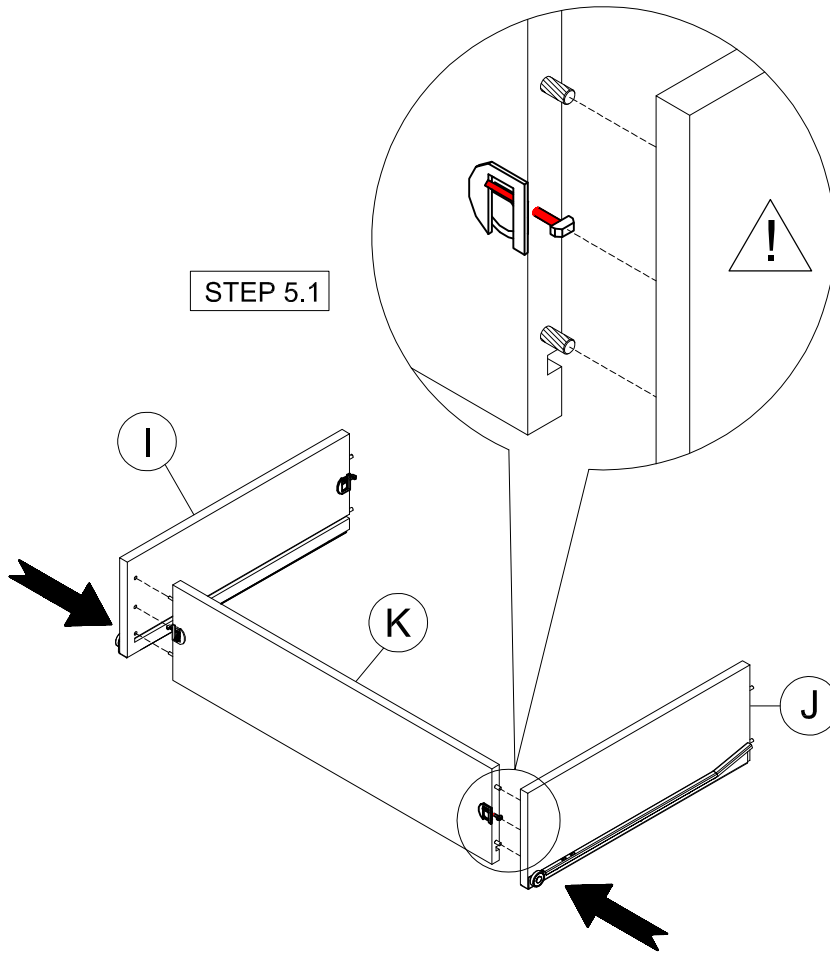

STEP 5.2

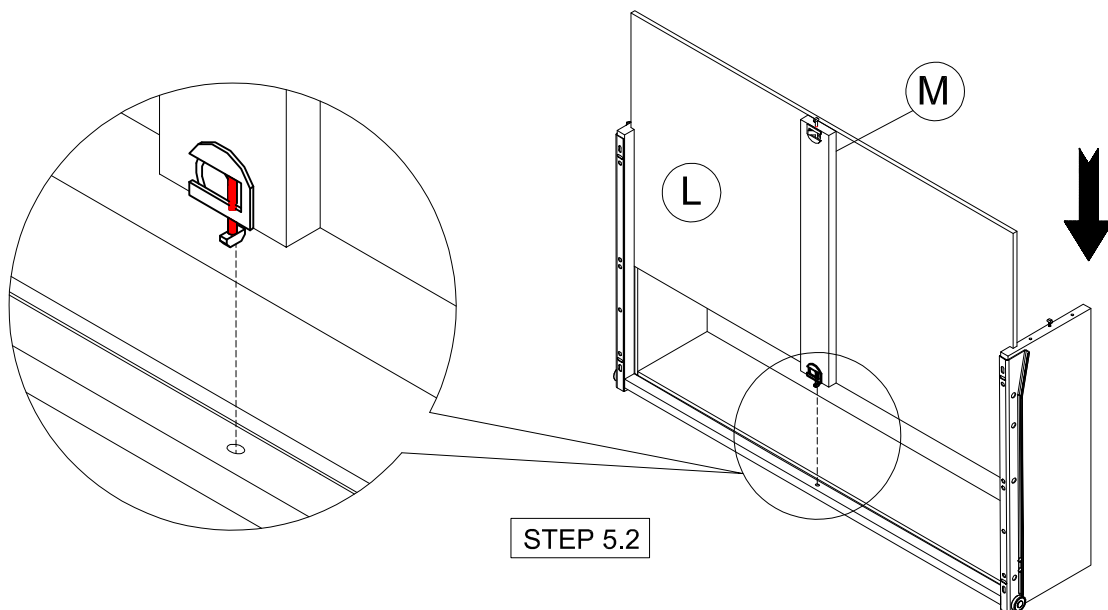

ASSEMBLY INTRUCTIONS / NOTICE DE MONTAGE / INSTRUCCIONES DE MONTAJE

ITEM / NO D' ARTICLE / ARTICULO : J010-010A/ B - 3000 & 3001

DESCRIPTION / DESCRIPCIÓN: DRESSER / COMMODE / TOCADOR

STEP 6 ÉTAPE 6 PASO 6

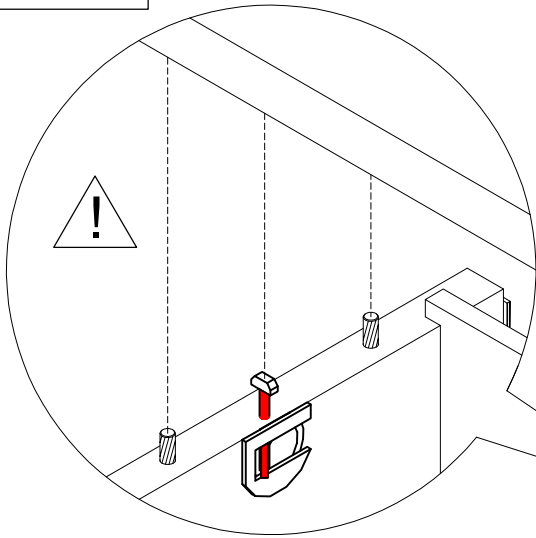

STEP 6.1

 **CAUTION**
MISE EN GARDE
PRECAUCIÓN

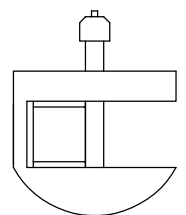

OPEN / OUVERT
ABIERTO

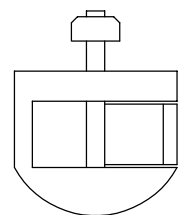

LOCK / VERROUILLÉ
BLOQUEAR

PLEASE ENSURE THUMB LOCK IN OPEN POSITION BEFORE ASSEMBLY.
VEUILLEZ VOUS ASSURER LE VERROUILLAGE DU BOUTON EN POSITION OUVERTE AVANT LE MONTAGE.
POR FAVOR, ASEGÚRESE DEL BLOQUEO DEL PULGAR EN POSICIÓN ABIERTA ANTES DEL MONTAJE.

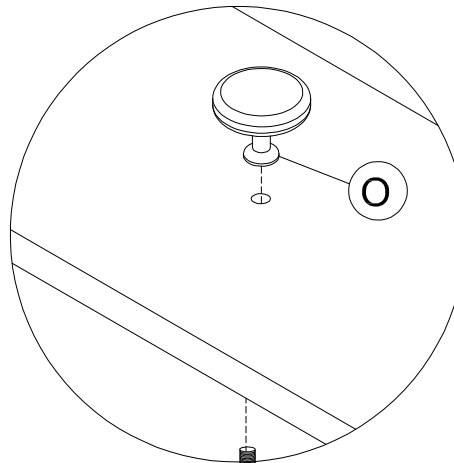

STEP 6.2

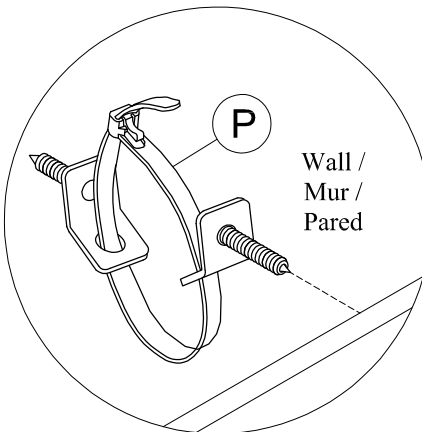

Wall /
Mur /
Pared

STEP 6.3